

*Operation-  
Instructions*

**for**

**ZÜNDAPP**

**Motorcycle**

**Model KS 601**

ZÜNDAPP-WERKE G. m. b. H., NÜRNBERG





**ZÜNDAPP**

**Motorcycle Model KS 601**

**Description  
and Operation Instructions**

**Published July 1953**



## Contents

|   | Page |
|---|------|
| <b>Introductory</b> . . . . .                   | 6    |
| <b>(A) Technical Details</b> . . . . .          | 7    |
| Engine . . . . .                                | 7    |
| Chassis . . . . .                               | 8    |
| Vehicle . . . . .                               | 9    |
| Gasoline and Oil Quantities . . . . .           | 10   |
| <b>(B) Description</b> . . . . .                | 11   |
| 1. Engine . . . . .                             | 11   |
| (a) Crankcase . . . . .                         | 11   |
| (b) Crankdrive . . . . .                        | 11   |
| (c) Cylinders and Cylinder Heads . . . . .      | 11   |
| (d) Valve Control . . . . .                     | 11   |
| (e) Lubrication . . . . .                       | 12   |
| (f) Oil Air Cleaner . . . . .                   | 12   |
| (g) Carburettor . . . . .                       | 12   |
| (h) Electrical Equipment . . . . .              | 13   |
| (i) Clutch . . . . .                            | 14   |
| 2. Drive Mechanism . . . . .                    | 14   |
| (a) Change-Speed Gear Unit . . . . .            | 14   |
| (b) Universal Joint Shaft . . . . .             | 15   |
| (c) Rear Axle Gear Unit (Final Drive) . . . . . | 15   |
| 3. Wheels, Tires, etc. . . . .                  | 15   |
| (a) Wheels . . . . .                            | 15   |
| (b) Tires . . . . .                             | 15   |
| 4. Frame Unit . . . . .                         | 16   |
| 5. Front Rear Wheel Springing . . . . .         | 16   |
| (a) Front Fork . . . . .                        | 16   |
| (b) Rear Wheel Springing . . . . .              | 16   |
| 6. Brakes . . . . .                             | 17   |
| (a) Foot Brake . . . . .                        | 17   |
| (b) Hand Brake . . . . .                        | 17   |
| 7. Hand and Foot Controls . . . . .             | 17   |



|  | Page      |
|--|-----------|
| 8. Tank, Fuel Tubing . . . . .                             | 17        |
| 9. Electrical Equipment . . . . .                          | 18        |
| (a) Battery . . . . .                                      | 18        |
| (b) Headlight . . . . .                                    | 18        |
| (c) Taillight . . . . .                                    | 18        |
| (d) Horn . . . . .   | 18        |
| (e) Distribution Box . . . . .                             | 18        |
| 10. Storing of the Tool Kit . . . . .                      | 18        |
| <b>(C) Operation . . . . .</b>                             | <b>19</b> |
| 11. Starting-up and Turning-off . . . . .                  | 19        |
| (a) Preparing to Take Off . . . . .                        | 19        |
| (b) Starting-up . . . . .                                  | 19        |
| (c) Turning-off . . . . .                                  | 20        |
| 12. Instructions for Driving . . . . .                     | 20        |
| (a) Gear Shifting . . . . .                                | 20        |
| (b) Braking . . . . .                                      | 20        |
| (c) Underway . . . . .                                     | 21        |
| (d) Cross-Country Riding . . . . .                         | 21        |
| <b>(D) Maintenance . . . . .</b>                           | <b>22</b> |
| 13. General . . . . .                                      | 22        |
| 14. Engine and Equipment . . . . .                         | 22        |
| (a) Lubrication . . . . .                                  | 22        |
| (b) Cylinder Heads, Intake and Exhaust Manifolds . . . . . | 23        |
| (c) Valves . . . . .                                       | 23        |
| (d) Oil Sump . . . . .                                     | 23        |
| (e) Oil Air Cleaner . . . . .                              | 24        |
| (f) Carburettor . . . . .                                  | 24        |
| (g) Electrical Equipment . . . . .                         | 24        |
| (h) Clutch . . . . .                                       | 25        |
| 15. Drive Mechanism . . . . .                              | 25        |
| (a) Change-Speed Gear Unit (Shift Gear) . . . . .          | 25        |
| (b) Universal Joint Shaft . . . . .                        | 25        |
| (c) Rear Wheel Gear Unit (Final Drive) . . . . .           | 25        |

|   | Page |
|---|------|
| 16. Wheels, Tires etc. . . . .                | 26   |
| (a) Dismounting the Front Wheel . . . . .     | 26   |
| (b) Dismounting the Rear Wheel . . . . .      | 26   |
| 17. Frame . . . . .                           | 27   |
| 18. Front and Rear Wheel Springing . . . . .  | 27   |
| (a) Front Wheel . . . . .                     | 27   |
| (b) Rear Wheel Springing . . . . .            | 27   |
| 19. Brakes . . . . .                          | 27   |
| (a) Foot Brake . . . . .                      | 27   |
| (b) Hand Brake . . . . .                      | 28   |
| 20. Hand and Foot Controls . . . . .          | 28   |
| 21. Tank, Fuel Tubing etc. . . . .            | 28   |
| 22. Electrical Equipment . . . . .            | 28   |
| (a) Battery . . . . .                         | 28   |
| (b) Current Consumers . . . . .               | 29   |
| 23. More Information on Lubrication . . . . . | 29   |
| 24. Survey of Maintenance Works . . . . .     | 30   |
| 25. Lubrication Diagram . . . . .             | 31   |



## Introductory

Zündapp motorcycles are designed according to the most modern construction principles, and under rigid engineering standards. They are manufactured from top-quality materials and built with utmost precision.

A machine that is properly serviced will obviously retain its value much longer than one which is neglected. It is, therefore, to your advantage if you study this booklet carefully.

The instructions contained herein are meant to acquaint you with your Zündapp model KS 601. We have subdivided this booklet into the following chapters:

- (A) Technical Details
- (B) Description
- (C) Operation
- (D) Maintenance

Chapter (A) — Technical Details — contains all data necessary for maintenance work.

**ZÜNDAPP-WERKE G.m.b.H., NÜRNBERG-MÜNCHEN**  
**WERK NÜRNBERG**

## (A) Technical Details

### Engine:

|  |   |
|--|---|
| Type of operation . . . . .                              | Four-stroke   |
| Stroke . . . . .   | 67.6 mm   |
| Bore . . . . .   | 75 mm   |
| Number of Cylinders . . . . .                            | 2   |
| Cubic Capacity . . . . .                                 | 597 c. c.   |
| Compression Ratio . . . . .                              | 1 : 6.4 ÷ 6.7   |
| Power Output . . . . .                                   | 28 HP at 4700 R. P. M.  |
| Engine Torque . . . . .                                  | max. 4.38 mkg at 3950 R. P. M.  |
| Piston Clearance<br>(with cold engine) . . . . .         | 0.08 mm   |
| Valve Play<br>(with cold engine) . . . . .               | Intake 0.20 mm<br>Exhaust 0.25 mm   |
| Valve Cycle (adjust with<br>1.0 mm valve play) . . . . . | Intake opens 12° before T.D.C.<br>Intake shuts 48° after L.D.C.<br>Exhaust opens 54° before L.D.C.<br>Exhaust shuts 6° after T.D.C.               |
| Battery-Lighting Set . . . . .                           | NORIS DS 6/50/70 Set<br>(automatic voltage control)<br>6 Volts, 50/70 Watts;<br>starting with No. 551844:<br>Noris DSa 6/90 L, 6 Volts, 90 Watts. |
| Ignition Adjustment . . . . .                            | by hand;<br>starting with No. 551844 automatic  |
| Ignition Timing . . . . .                                | Advanced ignition 10 mm (40°)<br>before T.D.C.  |
| Type of Sparkplug . . . . .                              | Bosch W 225 T 1 or<br>Beru K 225 b 1/14   |
| Distance between Plug<br>Electrodes . . . . .            | .0.7 mm   |
| Type of Battery . . . . .                                | 8 amp/h battery with internal<br>terminals  |
| Cooling System . . . . .                                 | Air Cooling   |
| Engine Lubrication . . . . .                             | Circulating type Lubrication  |
| Oil Pump . . . . .                                       | Gear Pump (automatic)   |
| Oil Consumption . . . . .                                | normaly 1 liter per 1,000 km<br>(600 miles)   |



Carburettor . . . . . Type Bing 1/25/1 left side  
 Type Bing 1/25/2 right side  
 Inlet Throughway 25 mm  
 Fuel Jet No. 105 left side  
 Fuel Jet No. 110 right side  
 Position of tapered needle:  
 Groove 2 (from top of needle)  
 Mixing Chamber Insert No. 5  
 Idler Jet No. 40  
 Air Adjusting Screw open  
 2—2½ turns

**Chassis:**

Frame . . . . . Closed double-tube frame,  
 torsion-proof welding  
 Front Fork . . . . . Tele glide fork  
 Springing . . . . . 4 Spring Coils  
 Shock Absorber . . . . . Single-action oil cushioned  
 Shock Absorber  
 Rear Wheel . . . . . Telescopic Springing  
 Clutch . . . . . Two-Disc Dry Clutch  
 Change-Speed Gear . . . . . ZÜNDAPP type Chain Gear  
 No. of Speeds . . . . . 4 forward

| Gear Ratio inside Gearbox | old      | starting with No. 551844 |  |
|---------------------------|----------|--------------------------|--|
| 1st speed . . . . .       | 1 : 3    | 1 : 3                    |  |
| 2nd speed . . . . .       | 1 : 1.8  | 1 : 6.625                |  |
| 3rd speed . . . . .       | 1 : 1.14 | 1 : 1.238                |  |
| 4th speed . . . . .       | 1 : 0.88 | 1 : 0.962                |  |
| Starter . . . . .         | 1 : 2.96 | 1 : 2.96                 |  |

| Total Ratios        | solo     | sidecar   | solo       | sidecar   |
|---------------------|----------|-----------|------------|-----------|
| 1st speed . . . . . | 1 : 16.1 | 1 : 18.4  | 1 : 14.625 | 1 : 18.4  |
| 2nd speed . . . . . | 1 : 9.66 | 1 : 11.05 | 1 : 7.922  | 1 : 9.982 |
| 3rd speed . . . . . | 1 : 6.07 | 1 : 6.94  | 1 : 6.035  | 1 : 7.605 |
| 4th speed . . . . . | 1 : 4.73 | 1 : 5.4   | 1 : 4.68   | 1 : 5.897 |

Transmission Agent from  
 Gearbox to Final Drive . . . . . Universal Joint Shaft

| Gear Ratio inside Rear Axle | old              |          | starting with No. 551844 |           |
|-----------------------------|------------------|----------|--------------------------|-----------|
|                             | solo             | sidecar  | solo                     | sidecar   |
| Gear Unit . . . . .         | 1 : 5.375        | 1 : 6.14 | 1 : 4.875                | 1 : 6.143 |
| Type of Drive . . . . .     | Rear wheel drive |          |                          |           |

Brakes:  
 Foot Brake . . . . . Rod type brake acting on rear wheel  
 Hand Brake . . . . . Cable brake acting on front wheel

Wheels:  
 Rim Size . . . . . 2.15 B x 19 (3 x 19)  
 Tire Size . . . . . 3.50 - 19 solo (both wheels)  
 4.00 - 19 for sidecar work, on  
 rear wheel (shallow tread);  
 For Snow Chain use:  
 3.50 - 19 on rear wheel

Tire Pressures:  
 Front Wheel . . . . . 1.5 atü (21.33 lbs/sq.in) solo  
 1.5 atü (21.33 lbs/sq.in) pillion  
 work  
 1.7 atü (24.17 lbs/sq.in) sidecar  
 work  
 Rear Wheel . . . . . 1.7 atü (24.17 lbs/sq.in) solo  
 1.9 atü (26.61 lbs/sq.in) pillion  
 work  
 2.0 atü (28.10 lbs/sq.in) sidecar  
 work  
 (with 4.00 - 19 tires)  
 Sidecar Wheel . . . . . 1.5 atü (21.33 lbs/sq.in)

**Vehicle Dimensions:**

Overall Length . . . . . 2140 mm  
 Width . . . . . 815 mm  
 Height . . . . . 1010 mm  
 Wheelbase . . . . . 1415 mm  
 Saddle Height . . . . . 740 mm  
 Turning Radius . . . . . 2300 mm  
 Weight (full tank, tools,  
 and tire pump) . . . . . 224 kg (494 lbs.)  
 with 4.00 - 19 tires  
 Peak Load . . . . . 464 kg (1014 lbs.)  
 with 4.00 - 19 tires  
 Minimum permanent speed . . . . . 4 - 5 km (3 miles)  
 Maximum speed . . . . . 135 km (85 miles)  
 Normal Gasoline Consumption . . . . . solo: 4.8 liters (1.27 gals.)  
 sidecar: about 5.5 l (1.45 gals.)  
 per 100 km (60 miles)  
 Maximum Range . . . . . 300 km (180 miles) solo  
 200 km (120 miles) with sidecar



**Gasoline and Oil Quantities:**

|                               |   |
|-------------------------------|---|
| Power Fuel:                   |   |
| Fuel Tank . . . . .           | 14 liters (3.70 gals.)<br>2 liters reserve of them  |
| Lubricants:                   |   |
| Engine . . . . .              | 2.5 liters (2.65 quarts)<br>with new engine<br>2.0 liters (2.12 quarts)<br>after oil change |
| Gearbox . . . . .             | 0.75 liters (0.81 quarts)   |
| Rear Axle Gear Unit . . . . . | 0.18 liters (0.19 quarts)   |
| Telescopic Fork . . . . .     | 0.15 liters (0.16 quarts)<br>per fork prong   |

German measures converted into:

- Quarts (US) liquid
- Gals. (US) liquid

**(B) Description**

**1. Engine (fig. 3)**

**(a) Crankcase**

The light alloy Crankcase is a one-piece casting and, in combination with the rear Crankshaft Bearing Cap, houses the crank mechanism. On its underpart it carries a detachable Oil Sump.

**(b) Crankdrive**

The Crankdrive comprises Crankshaft, Connecting Rods, and Pistons. The Crankshaft is a one-piece forging. It is hardened and mounted in three exchangeable Ball and Roller Bearings. The Connecting Rods have split big ends. The pins of the Connecting Rod Bearings on the crankpin are guided in split bronze rings (cages). The small end of the connecting rod holds the Piston Pin Bush. The pistons are provided with three Compression Rings and an Oil Scraper Ring each. The oil grooves in the scraper rings are provided with bypass ducts leading into the piston interior. The Piston Pin floats, and is secured against lateral dislocation.

**(c) Cylinders and Cylinder Heads**

Both oppositely arranged special cast-iron Cylinders are flanged to the crankcase by means of staybolts. The light alloy Cylinder Heads are oil-sealed by means of removable caps. They carry the Rocker Arms for the Valve Control.

**(d) Valve Control**

The Camshaft controls the valve cycle. It lies overhead the Crankshaft and is mounted in a fore and rear Roller Bearing inside the Crankcase. The Camshaft is driven by the helically toothed Crankshaft Gear which engages the noise and vibration-absorbing Camshaft Gear. A camshaft-controlled Rotary Shutter operates the ventilation. The valves are controlled by the camshaft over Valve Tappets, Valve Pushrods, and Rocker Arms provided with Adjusting Screws. The hollow mushroom type Tappets slide in exchangeable Guides. They are made of light alloy with pressed-in cast Tappet Plates, and hardened Ball Sockets. The Pushrods are made of light alloy and have pressed-in hardened steel ends. The mushroom Tappet holds the ball-shaped lower end of the Valve Pushrod. The ball-socket upper end of the pushrod touches the spherical end of the Rocker Arm Adjusting Screw. The Rockers are mounted in Needle Bearings on the Cylinder Heads.



The tulip-shaped overhead Valves are arranged in inclined position. This renders the Combustion Chamber almost semi-spherical. Valves are shut by Valve Springs (two for each valve). The Valve Guides are forced into the Heads. The Valve Seat Rings are shrunk into the Heads.

**(e) Lubrication** (fig. 5)

The Circulating Lubrication is operated by a Gear Oil Pump driven by the crankshaft over a Spur Gear. The Oil Pump sucks the oil, through a Filter Unit, out of the Oil Sump and forces it, through a system of oil ducts in the crankcase, towards the nozzles. Through the nozzles the oil is sprayed against the Crank Journals which are provided with oil grooves. The hollow crankpins receive the oil for the Connecting Rod Needle Bearings from one of these grooves. Crankshaft and Camshaft Bearings, Cylinder Barrels, and Tappets are lubricated by oil splash. Through the hollow Tappets and Pushrods the oil travels towards the hollow Rocker Arms, the Rocker Arm Bearings, and the Valve Guides. Driving Gears for Camshaft and Oil Pump are lubricated by fine oil spray in the front Crankcase Cover. Surplus oil from the Valve-Chambers flows back to the Oil Sump through oil bypass ducts.

**(f) Oil Air Cleaner**

The Oil Air Cleaner consists of a Vortex-Action Filter Jacket made of sheet metal, a Filter Bottom, and a perforated Filter Cap. It is fastened to the Crankcase with a winged screw. The oil film on the filter jacket absorbs all dust, grit, or other foreign matter.

**(g) Carburettor** (fig. 6)

With Bing Downdraft Carburettors, Mixing Chamber and Float Chamber form a one-piece unit. A compensating bore beside the Mixing Chamber guarantees a uniform fuel level at the Main Jet, regardless of the motorcycle's position.

The carburettor's task is to provide the engine, under varying degrees of load, with a rich, and correctly measured, fuel-air mixture. The mixing operation is done by an Idler - and - Main - Jet System. Within the lower speed range the engine receives the fuel - air mixture from the Idling System which consists of Idler Jet (for fuel supply), Idler Air Jet, and Air Screw.

Throttling down the air admission by means of the Air Screw means richer mixture. Admitting more air renders the mixture leaner. The Idler Jet is interchangeable.

With increasing speed, the Main Jet System starts working. It comprises Main Jet, Mixing Chamber Insert, and Needle Jet. The

interchangeable Main Jet is situated at the lower needle jet end. The Needle Jet is screwed into the Carburettor Body from below. When the Main Jet System starts operating, the fuel passes through the Main Jet towards the Needle Jet. The needle jet opening points into the Mixing Chamber where fuel and air are subjected to a premixing process. The area of the needle jet opening is varied by a Tapered Needle affixed to the Gas Slide. Whenever the Gas Slide is actuated the needle will dive into the Jet Body and the area of the jet opening will be reduced; whenever the needle is withdrawn the opening area will increase. The Needle Body is provided with grooves for needle adjustment in the Gas Slide. Whenever the needle is set so that it, in its initial position, enters the opening deeper, the engine will receive a leaner mixture. Whenever it is set higher, the mixture will become richer. The Needle Jet, however, can only influence fuel consumption while the engine is throttled down. With Gas Slide fully open, fuel consumption is exclusively governed by the Main Jet.

**(h) Electrical Equipment**

The Electrical Equipment of the engine comprises the Magdyno (Battery-Generator Set), the Ignition Coil, and the Sparkplugs. The D. C. Shunt-wound Generator with automatic voltage control has a capacity of 50/70 Watts at 6 Volts, starting with No. 551844 capacity of 90 Watts at 6 Volts. It is flanged to the front Crankcase Cover. The Armature Shaft, on its fore end, terminates into a Breaker Cam. The adjustable Contact Breaker is situated at the front end of the casing. It is protected by a cap. The Plugs are screwed into the Cylinder Heads in inclined position. Voltage Regulator and Reverse-Current Cut-Out are situated on top of the casing under a sheet-metal cap. Armature Shaft and Crankshaft are joined.

The Voltage Regulator balances the generator's terminal voltage and keeps it practically constant regardless of load and speed. The battery is automatically charged with high primary tension. There is no danger of overcharging it.

The Reverse Current Cut-Out serves to connect battery and generator parallel whenever the tensions of both are equal.

With increasing speed, the Voltage Regulator completes, or closes, the circuit between battery and generator; the battery is being charged.

With decreasing speed, as soon as a certain amount of reverse current flows back from the battery, the Voltage Regulator breaks



the circuit, thereby preventing the battery from discharging via the generator. The red Warning Light in the Headlight Cowl will then light up.

### (i) Clutch

The engine's torque is transmitted to the Change-Speed Gear Unit over a Dry Multiple Disc Clutch. It comprises Flywheel, Pressure Springs, Spring Carrier, Clutch Discs, Clutch Center Plate, and Clutch Cover Plate. (Plates = driving members; Discs = driven members.)

Spring Carrier, Center Plate, and Cover Plate are guided by the flywheel's internal Spline. The Clutch Discs are provided with bilateral Lining, and are guided in the Main Shaft's female Spline. 8 Pressure Springs supply the necessary contact pressure.

**Clutch Action:** The Clutch Hand Control, when pulled towards the handlebar, operates the Clutch Lever situated at the Starter Cap. The latter exerts pressure over a Thrust Rod, onto the Spring Carrier, thereby compressing the springs, and relieving the discs. (Declutching.)

When the Hand Control is released ("in"-position), discs and plates are pressed together by the Spring Carrier (which is under constant spring load), and the main shaft is being driven.

## 2. Drive Mechanism

### (a) Change-Speed Gear Unit (fig. 4)

The Change-Speed Gear Unit is a chain-type transmission with four forward speeds. The one-piece Engine-Gear Unit has shockproof rubber cushioned suspension. The gearbox is flanged to the crankcase. It contains the Shafts, Chains, and Gears, the Gearshift Mechanism, and the Starter System. The speeds are shifted by means of sliding jaws. Gears and chains are constantly in mesh and do not slide during the gearshifting process. The Reduction Gear Shaft (Back Gear Shaft) is driven by the Sliding Jaws which mate with the holes in the gears on the Reduction Shaft. Main and Reduction Gear Shafts are mounted in Ball Bearings in the Gearbox. The Shifting Mechanism with the Shifting Forks is situated at the right-hand Gearbox side. The elastically affixed Shifting Forks allow all four speeds to be engaged even when the engine is not running. The Gearshifting Mechanism is operated by the Foot-Change Control. The Starter is situated at the left-hand gear-box side. The Starter, when depressed, transmits the power to

the Main Shaft over Bevel Gears and a big and a small sliding Spur Gear. The Spur Gear's face is provided with driver tothing, and meshes with a corresponding gear on the Main Shaft. The latter gear can be driven in one direction only; thus the Spur Gear has been made slideable on the Main Shaft.

The Reduction Gear Shaft's end is joined with the Universal Joint Shaft fore end.

### (b) Universal Joint Shaft

The Universal Joint Shaft acts as transmission agent from engine to Rear Axle Gear Unit (Final Drive). It is provided, near the shaft ends, with Universal Joints mounted in Pin Bearings. Both shaft ends, at the gear unit as well as at the final drive end, are slideable. The Universal Joints are protected against dust, dirt, and other foreign matter.

### (c) Rear Axle Gear Unit (Final Drive) (fig. 7)

Rear Axle Gear Unit and rear right-hand part of the Tele-Glide Suspension are a one-piece unit. The former contains the helically toothed Bevel and Spiral Drive Gears for the Final Drive, as well as helically toothed gears for the Speedometer Drive. The Universal Joint Shaft is joined with the Bevel Gear's fore end. Spiral Drive Gear and Rear Wheel Drive Gear are also joined.

## 3. Wheels, Tires etc.

### (a) Wheels

The motorcycle's wheels are equipped with Deep-Center Safety Rims 2.15B x 19 (3 x 19) and Re-enforced-End Spokes. The wheels are interchangeable. Wheels and Hub Bodies are joined with the motorcycle by means of Left-Hand Thread Hollow Screws. With sidecar attached to the motorcycle's right-hand side, the Sidecar Wheel is fastened by means of a Right-Hand Thread Hollow Screw, with left-side attached sidecar it is fastened by a Left-Hand Thread Hollow Screw.

### (b) Tires

For solo machines generally Steel Wire-Re-enforced Low-Pressure Tires 3.50 - 19 are used. With sidecar outfits it is advisable to use 4.00 - 19 Shallow Tread Tires on the rear wheel, for longer tire life. For pillion - and - sidecar work this is absolutely necessary. When driving with anti-skid chains the 3.50 - 19 tire must also be used on the rear wheel.



#### 4. Frame Unit

The motorcycle's closed frame consists of drawn steel tubes welded to the steering head and made twist-proof by means of cross stays.

#### 5. Front and Rear Wheel Springing

##### (a) Front Fork (fig. 9)

The Telescopic Fork's Shank is mounted in ball bearings and has a two-point suspension at the steering head, the upper and lower Fork Cross Members. The lower Fork Guide Tubes slide on the hard-chromed Fork Tubes fastened to the two Cross Members. The Fork Guide Tubes, on their lower ends, have jaws which allow quick wheel dismounting without detaching any of the clamping screws completely. For better cushioning purposes each tube has been provided with a Coil Spring Unit, which consists of a pre-loaded short lower spring and a stronger long spring over the former.

Both springs are connected by means of a Spring Seat and a Tension Bolt in such a way as to enable the short spring, under normal load, to iron out all minor shocks. Only under heavier loads the strong upper springs start functioning. An Oil Damper situated between the upper Fork Guide Tubes and the upper Cross Member acts as cushioning medium while the fork is relieved of stress. A Steering Damper mounted at the Fork Shank prevents the fork from shaking and vibrating when the sidecar is attached, or when the motorcycle goes over rough ground. The Steering Damper can be manually adjusted free from play by Adjusting Screws. Each Fork Leg is filled with 150 c. c. of oil in order to prevent the sliding tubes from seizing. (See Lubrication Diagram page 31.)

For sidecar work the pre-loading of the short springs in the Spring Unit must be increased by about 30 mm, and the difference equalized by a Spacer.

##### (b) Rear Wheel Springing (fig. 8)

Like the Front Fork, the motorcycle's Rear Wheel Springing operates after the telescopic principle. Pilot Bushes are mounted at the upper and lower frame ends. The Guide Tubes fastened to the Final Drive Unit Casing and the left-hand Spring Guide slide in these bushes. A Pressure Spring on each side bears the wheel load and an Absorption Spring guarantees soft cushioning in center

position. Complete enclosure prevents dirt, grit, and other foreign matter from entering the spring mechanism.

#### 6. Brakes

##### (a) Foot Brake (fig. 11)

The Foot Brake is an internally acting rod-type brake acting on the rear wheel. The Brake Pedal is adjustable.

##### (b) Hand Brake

The Hand Brake is an internal-type brake within the Front Wheel Hub. It can be applied by pulling the Brake Hand Control at the right handlebar side which again actuates Control Cable and Brake Lever.

When brake is applied, Brake Shoes are forced apart by the Brake Cam. The Brake Shoes are mounted on the Brake Cap. When brake is released, the Brake Shoes are retracted to their initial positions by the Brake Release Spring.

#### 7. Hand and Foot Controls (fig. 10)

The motorcycle is equipped with the following hand and foot controls:

Hand Clutch Control, Ignition Lever, and Dipper with Horn Button are mounted at the left handlebar side. The handlebar's right hand side carries Hand Brake Control and Twist-Grip.

Starter and Foot-Change Control are mounted at the left-hand side of the Engine-Gear Unit. On its right side is the Foot Brake Pedal which is connected with the Rear Wheel Brake Lever over Brake Rigging.

#### 8. Tank, Fuel Tubing, etc.

The Fuel Tank is suspended at the upper part of the Frame Unit. It contains 14 liters (3.70 gals.) and has two Three-Way Taps provided with Fuel Strainers. The strainers are manufactured of fine-mesh wire sieve which collects all impurities contained in the fuel. The strainer can be easily detached and cleaned. With both Three-Way Tap Levers pointing towards "Auf" (Open), only 12 liters (3.20 gals.) can be consumed. For Fuel Reserve (about 2 liters) turn Tap Levers towards "Rest" (Reserve).

The Reserve has been installed with the intention to remind the driver to refuel the motorcycle in time. Keep Fuel Taps closed



while the engine is not running. Fuel Tank and Carburettor are connected by means of Fuel Tubing.

## 9. Electrical Equipment (fig. 12)

The motorcycle is equipped with a 6 Volt Lighting-Ignition Set.

### (a) Battery

The Battery is situated at the left-hand gearbox side, out of harm's way. It is kept in place by an elastic clamp. Battery capacity is 8 ampere-hours.

### (b) Headlight

The Headlight is fastened to the Tele-Glide Fork. It contains an Anti-Dazzle Lamp for bright and dimmed light, a Parking Lamp, a red Ignition Warning Light, a built-in Speedometer with lighting, and an Electroswitch for the Lighting Set which also contains the Electrolock with removable Ignition Key for switching on, or off, the ignition. The Headlight Cowl is completely sealed. The reflector inside is protected from dust and water spray. The lamps are securely fastened to the reflector. No adjusting necessary. Lights are dimmed by the Dip Switch at the left handlebar side which also bears the Horn Button.

### (c) Taillight

The Taillight is situated at the lower part of the Rear Fender and illuminates the license plate.

### (d) Horn

The Horn is elastically fastened to the frame below the saddle. It is sounded by pressing a button at the Dip Switch at the left handlebar side.

### (e) Distribution Box

The Distribution Box for the Sidecar Light is fastened to the toolbox under the saddle.

## 10. Storing of the Tool Kit

The tools are stored in a locked toolbox under the saddle.

## (C) Operation

## 11. Starting-up and Turning-off

### (a) Preparing to Take Off

Before taking off, check whether

1. there is the correct amount of the right type of oil in the engine, the gearbox, and the rear wheel gear unit,
2. the fuel tank is filled up,
3. the battery is charged,
4. tire pressure is correct,
5. the whole motorcycle is thoroughly greased,
6. the brakes are in good working condition.

### (b) Starting-up

1. Move Foot-change Control into "Neutral".
2. Open fuel taps. (Position "Auf")
3. Flood carburettor by depressing both ticklers simultaneously.
4. Open throttle twist-grip about one-fourth. Depress kickstarter one to three times with clutch engaged and ignition switched off (red ignition warning light must not light up).
5. Switch on the Ignition (warning light lights up). Open throttle twist-grip slightly, move ignition timing control into retarded position, i. e. move it anti-clockwise to extreme position (Attention: Starting-up in advanced position may cause the starter to deal vicious kicks!), and then start-up by depressing the starter.
6. Lower engine's speed by closing the throttle. High speed with insufficient operation temperature is extremely harmful to the engine. Especially under temperatures below 10°C the engine should be allowed to warm up while running light.

NB: Starting-up without, or with defective, battery.

An almost discharged, or defective, battery will make starting-up difficult. An engine without, or with defective, battery must be started-up by pushing the motorcycle. It is best to disconnect the battery from the earth lead at the negative pole. Pushing is made easier by connecting the generator terminals No. 6 and 9 by means of a piece of copper wire. The wires already



connected to above mentioned terminals must, however, stay where they are. After a new battery has been mounted the piece of wire should be removed.

### (c) Turning-off

1. Move foot-change control into "Neutral". When parking the motorcycle on a gradient, move in 1st speed after the engine is turned off.
2. Close fuel taps.
3. Increase speed of the engine by accelerating.
4. Remove ignition key and close throttle twist-grip.

## 12. Instructions for Driving

### (a) Gear Shifting

Always start with 1st speed and change — whether up or down — in strict sequence only.

1. Declutching: Pull clutch control closely towards handlebar. Move in 1st speed by depressing the foot-change control. Release clutch control gradually, and accelerate.
2. Changing up: Close twist grip — declutch — press foot-change control upward — release clutch control — accelerate.
3. Changing down: Declutch — depress foot-change control — engage clutch.

### (b) Braking

Try to regulate your speed with a minimum of brake use. Reduction of speed can, in most cases, be achieved by closing the throttle in time.

#### 1. Foot Brake

When operating the foot brake, start off pressing the pedal slightly, and gradually increase pressure.

#### 2. Hand Brake

It is advisable to apply the hand brake carefully, even on rougher roads.

In case of danger: Decelerate, depress foot brake pedal swiftly, (not abruptly) and pull hand brake. Avoid blocking the wheels as this usually results in skidding and damage to the tires. When

driving on wet and slippery roads, apply brakes very carefully. On prolonged downhill drives always move in lower gear. Your four-stroke engine is the best and most dependable brake!

### (c) Underway

Drive carefully while going through built-up areas, over bridges, on slippery roads, and through curves. Avoid abrupt braking by decelerating, and changing-down, before reaching dangerous places. Pay attention to clutch slippage, for it means excessive clutch wear. Always make use of the engine's braking power. Avoid low speed in high gear. Change down in time. Use the same gear going down a hill that you would use climbing it. Never try to change gear while driving downhill. Better do it before!

While the motorcycle is driving along smoothly, the twist-grip should be closed shortly from time to time. This will create a vacuum in the combustion chamber and the oil film in the cylinders will be renewed. No overheating the engine can occur.

### (d) Cross-Country Riding

During cross-country riding the correct operation of steering mechanism, brakes, clutch, and change-speed gear is of the utmost importance. On sand or other loose soil, a minimum of steering is advisable. Swinging the front-wheel too much will make the motorcycle skid whenever it hits solid ground again. Enter all curves carefully. Also during cross-country riding, clutch slippage must be avoided.



## (D) Maintenance

### 13. General

Careful maintenance and operating your motorcycle according to instructions will keep it in good working condition. Each machine leaving our factory is equipped with accessories and tools for maintenance.

Once or twice a year the motorcycle should be thoroughly cleaned. All parts where access is difficult should be greased. Rims, if damaged, must be derusted and revarnished. Retightening of screws and bolts, especially on the cylinder heads, cylinders, oil sump, and oil drain plugs, is very important. New, or overhauled, engines should be run-in carefully according to instructions below.

| Running-in speed limits:         | solo  | sidecar work                          |
|----------------------------------|---|---------------------------------------|
| 0—1000 km<br>(0—600 miles)       | 1st speed 25 km/h (15 miles)                    | 20 km/h (12 miles)                    |
|                                  | 2nd speed 35 km/h (20 miles)                    | 30 km/h (18 miles)                    |
|                                  | 3rd speed 60 km/h (36 miles)                    | 50 km/h (30 miles)                    |
|                                  | 4th speed 75—85 km/h (45—50 miles)<br>(varying) | 65—75 km/h (40—45 miles)<br>(varying) |
| 1000—2000 km<br>(600—1200 miles) | 1st speed 30 km/h (18 miles)                    | 25 km/h (15 miles)                    |
|                                  | 2nd speed 40 km/h (24 miles)                    | 35 km/h (20 miles)                    |
|                                  | 3rd speed 75 km/h (45 miles)                    | 65 km/h (40 miles)                    |
|                                  | 4th speed 90—95 km/h (55—58 miles)<br>(varying) | 80—85 km/h (48—50 miles)<br>(varying) |

During the running-in period, the maintenance works indicated must be performed. Maintenance works referred to on page 23, and marked by a vertical line on the page margin should be performed by a workshop. All other maintenance work may be performed by the motorcycle's owner. The vehicle is equipped with the necessary tools and spares.

### 14. Engine and Equipment

#### (a) Lubrication

With new engine, oil should be changed

|                               |                       |
|-------------------------------|-----------------------|
| after                         | 500 km (300 miles)    |
| after the next                | 500 km (300 miles)    |
| after another                 | 1000 km (600 miles).  |
| From then on change oil every | 3000 km (1800 miles). |

The oil (re types of oil consult Lubrication Diagram page 31) is drained out by loosening the Oil Drain Plugs on the Oil Sump's underpart. It is best to change oil immediately after a prolonged

drive when the oil is still warm and fluid enough. In tropical and dusty areas oil should be changed every 2000 km (1200 miles) regularly. Oil consumption is 1 liter per 800 km (480 miles).

From time to time the oil level should be checked by means of the Oil Measuring Rod. The latter is situated near the Filler Screw behind the left-hand cylinder. It carries two marks, the upper mark indicating "ZU VIEL" (too much), and the lower "ZU WENIG" (too little). Before measuring the oil level clean area around the filler. Insert rod into the Filler Hole, but don't screw it in! If the oil level registers at, or below, the ZU WENIG mark, more oil should be added. A correct oil level will register midway between the two marks, provided the motorcycle stands evenly.

#### (b) Cylinder Heads, Intake and Exhaust Manifolds

With new, or overhauled, engine the Cylinder Flange Nuts and the nuts on the cylinder heads should be retightened in diagonal order after the first 300 km (180 miles). After another 500 km (300 miles) retighten Intake and Exhaust Manifold Nuts.

#### (c) Valves

With new, or overhauled, engine, valve play should be checked after the first 500 km (300 miles), then again regularly after every 2000 km (1200 miles). For better rocker accessibility remove head caps. Depressing the Starter slowly will turn the crankshaft until both valves in one cylinder intersect. This constitutes Dead Center Position for the opposite cylinder. Valve play is generally measured with cold engine in D. C. P. Correct valve play, between Valve Pushrod and Rocker, should measure 0.20 mm at the Intake, and 0.25 mm at the Exhaust. For measuring use gauge contained in the Tool Kit. Loosen Lock Nuts and adjust Rocker Screws with gauge inserted rigidly, as valve play will again increase after the Lock Nuts have been retightened.

After having adjusted the valve play, retighten Lock Nuts and grease rockers generously. Before screwing down the Head Caps, check whether the oil seals are in correct position, and no loss of oil can occur.

#### (d) Oil Sump

Every 10000 km (6000 miles) the Oil Sump should be dismantled and thoroughly cleaned. Oil Sump Seals, if worn out, must be replaced. A new Oil Strainer should be mounted. Retighten Oil Sump Screws in correct (diagonal) order. Re correct amount of oil consult Lubrication Diagram (page 31).



**(e) Oil Air Cleaner**

The Air Cleaner should be cleaned as often as possible. Loosen winged screw and take out filter. Rinse it in gasoline and blow it through with a tire pump. Dip it into motor oil. Screw it in place by means of the winged screw.

**(f) Carburettor**

Every time the engine shows a tendency towards irregular running the Carburettor should be readjusted and cleaned. For access to Main Jet loosen Union Screw. Gas Slide and Jet Needle can be easily detached after the Mixing Chamber Cover has been removed. Take out the Needle Jet. The Mixing Chamber Insert is then accessible. Float and Float Needle can be taken out after the Float Chamber Cover has been taken off the Float Chamber.

Before reassembling the Carburettor, it should be thoroughly cleaned with gasoline. The same applies to the Air Filter. All data necessary for adjustment are contained in "Technical Details" (page 7).

Adjusting the engine is done in the following way:

Warm up the engine to proper working temperature. Control Cable Adjusting Screws in the Mixing Chamber should be screwed in completely. Move Ignition Control into "Retarded" position. Detach Ignition Cable from the nearside cylinder and adjust the offside carburettor. Screw in Gas Slide Stop Screw until engine continues running with twist-grip closed. Unscrew Air Screw until engine runs with highest possible speed. Then unscrew Gas Slide Stop Screw as far as it is necessary for smooth and balanced idling.

Adjust the second Carburettor in the same way, attaching the Ignition Cable to the nearside cylinder and detaching it from the offside one. The Air Screw's setting range is 2—2½ turns from closed position, depending on temperature conditions.

Control Cables on both carburettors should be adjusted in such a way as to make both Gas Slides open simultaneously. Also, both wires should have exactly the same amount of slackness.

Adjust Gas Slide Stop Screws in exactly the same manner so that both cylinders show smooth and balanced idling.

**(g) Electrical Equipment**

Every 10000 km (6000 miles), or every time the red Ignition Warning Light fails to go out, the Carbon Brushes of the generator should be checked, with the Protecting Cap removed. If the springs

are found to touch the Brush Holders the brushes are worn out and must be replaced. Check Breaker Contacts every 5000 km (3000 miles) and clean Contact Faces. Oxydized spots should be cleaned with a fine file, and smoothed. Do not use emery cloth or paper because it will disintegrate and leave tufts of paper fibre behind.

With contacts fully open, the gap between them should measure 0.3—0.4 mm (0.12—0.16 in.). Measure the gap every time you clean the contact faces, and adjust in the following way:

Loosen both Clamping Screws. Turn Eccentric until gap is correct. Retighten screws. Provide Grease Felt with Mobiloil C.W. Plugs should be cleaned with a steel brush or gasoline. Check gap between Plug Electrodes according to Chapter "A" (page 7).

**(h) Clutch**

The Clutch must be completely engaged without clutch slippage. With Clutch correctly adjusted, the Clutch Hand Control on the handlebar should show a small amount of slackness. Adjust clutch by means of a Knurled Edge Nut on the Clutch Control Cable.

**15. Drive Mechanism**

**(a) Change-Speed Gear Unit (Shift Gear)**

Check oil level every 1000 km (600 miles) and refill if necessary. Every 10000 km (6000 miles) the oil in the gearbox should be changed. If possible, change oil immediately after a prolonged drive, as long as it is still warm and fluid enough. The Oil Drain Plug is situated at the underpart of the gearbox. The Oil Filler is at the right-hand side of the gearbox. Correct oil level will register at the Oil Filler. With new, or overhauled, gear, oil should be changed after 2000 km (1200 miles).

**(b) Universal Joint Shaft**

Every 10000 km (6000 miles) the Grease Nipples on the Universal Joint Shaft should be provided with lubricant.

**(c) Rear Wheel Gear Unit**

Check oil level every 1000 km (600 miles) and refill, if necessary. Re correct type of oil consult Lubrication Diagram (page 31). Change oil every 10000 km (6000 miles), if possible, immediately after a



prolonged drive, as long as the oil is still warm and fluid. Correct oil level will register at the Oil Filler. With new, or overhauled, Rear Wheel Gear Unit, oil should be changed after 2000 km (1200 miles).

The Oil Drain Plug is at the Gear Unit's underpart.

**Attention!** In case of noisy gear operation check oil level immediately. Loose Oil Drain Plugs may cause loss of oil.

## 16. Wheels, Tires etc.

### (a) Dismounting the Front Wheel

Prop up the motorcycle on Front and Center Stand. Lift Brake Lever and detach Brake Cable. Loosen hexagonal screw on front axle (right-hand side). Loosen big hexagonal screws on Prong Ends only until Jaws open, and front wheel together with axle is easily detachable.

### (b) Dismounting the Rear Wheel

Three hexagonal Nuts on the rear Fender Tip should be loosened only, not completely detached, and Fender Tip detached. The Center hexagonal Nut also holds the Taillight Connection. Attention when reassembling!

1. Loosen Clamping Bush on left-hand side  
(Attention! Left-hand thread!)
2. Prop up motorcycle on Center Stand
3. Loosen hexagonal nut at Spring Guide  
Take out Stub Axle (Right-hand thread)
4. Detach Rear Axle and swing left Spring Guide Unit outward until Clamping Bush is accessible. Take it out and detach wheel.

The tires must always be in good condition and should be changed in time. If possible, check tire pressure every time the fuel tank is refilled.

Correct tire pressures are:

|                   |         | solo    | pillion work | pillion-and-<br>sidecar work |
|-------------------|---------|---------|--------------|------------------------------|
| for Front wheel   | 3.50—19 | 1.5 atü | 1.5 atü      | 1.7 atü                      |
| for Rear wheel    | 3.50—19 | 1.7 atü | 1.9 atü      | —                            |
| for Rear wheel    | 4.00—19 | —       | 1.9 atü      | 2.0 atü                      |
| for Sidecar wheel | 3.50—19 | —       | —            | 1.5 atü                      |

(1 atü equalling 14.22 lbs./sq. in.)

## 17. Frame

Every 5000 km (3000 miles) the Pressure Nipples in the Frame Unit should be greased. Re types of lubricants consult Lubrication Diagram (page 31). Retighten all Clamping Bolts.

## 18. Front and Rear Wheel Springing

### (a) Front Wheel

The oil contained in the Tele-Glide Fork should be drained out regularly every 5000 km (3000 miles). For this purpose loosen Oil Drain Plugs at the lower prong ends and screw them in again after the oil has been drained out.

Provide each prong with 150 c. c. (1.6 qts.) Motor Oil SAE 40 for outside temperatures above plus 15° C

or 150 c. c. (1.6 qts.) Motor Oil SAE 20 for outside temperatures below plus 15° C.

For the purpose of refilling the Fork Blades take out Rubber Stoppers at the upper Fork Blade Ends.

Use the correct type of oil adapted to prevailing temperature conditions. The type of oil you use will greatly influence the Fork Tube's working properties. Thin oil will render the cushioning softer, use of thick oil will result in harder riding.

### (b) Rear Wheel Springing

Every 5000 km (3000 miles) the Pressure Nipples on the upper spring guide should be greased.

## 19. Brakes

The Brake Linings must be kept free of water and oil. If, by driving on wet roads, or by washing down the motorcycle, water should succeed in entering the brakes, it is best to drive for a short stretch with brakes applied slightly until brake operation is satisfactory. Brake Shoes must never scrape while brakes are in "off" position.

### (a) Foot Brake

The Foot Brake can be adjusted by turning the Spring Nut at the Brake Rigging.



### **(b) Hand Brake**

The Hand Brake can be adjusted by turning an Adjusting Screw Bolt with Lock Nut at the lower Fork End.

### **20. Hand and Foot Controls**

Every 1 000 km (600 miles), and every time the motorcycle is cleaned, the Fulcrums of all Hand Controls should be oiled. Also the Foot-Change Gear Rigging Joints should be provided with a few drops of oil.

### **21. Tank, Fuel Tubing etc.**

Every 5 000 km (3 000 miles), retighten the Clamping Bolts at the Fuel Tank Suspension and check whether the Fuel Tap Clamping Nuts have close fit. The Fuel Strainer is situated at the Three-Way Tap.

Move Fuel Tap into "closed" position and unscrew the Strainer Cup which, at the same time, serves as water collector.

Loosen Eye Nut, detach Strainer Insert from below, and clean it with a soft brush. When reassembling, check whether the Packing Ring is in correct position.

### **22. Electrical Equipment**

#### **(a) Battery**

Every 1 000 km (600 miles), or every time the light fades rapidly during night rides, the battery at the left-hand gearbox side should be checked. The acid level should be not higher than 8 mm above the Plates; otherwise the battery will lose acid through the stoppers. For refilling use distilled water from a clean receptacle. Never use acid.

Screw in Stoppers tightly. Keep battery clean and dry, and wipe off exuded acid on the outside. Terminals and Pole Tops must be greased.

When testing the battery, check acid level by means of an acidometer.

Especially during wintertime the battery should be kept in a good state of charge. Any battery will freeze at about

- 18° C when three-fourths discharged
- 8° C when completely discharged.

### **(b) Current Consumers**

Check Lighting Set every 5 000 km (3 000 miles). All connections must have good contact. Repair frayed wires with insulating tape. Prior to any repair work on the battery or on any other electrical equipment the positive pole should be disconnected. Check (with correct tire pressure and motorcycle loaded to full capacity) whether the Headlight is correctly adjusted.

### **23. More Information on Lubrication**

All Grease Nipples, Oil Fillers etc. on engine and frame are indicated in the Lubrication Diagram (page 31). Make sure that only the type of oil indicated is used for the individual lubrication points. Clean Nipples, Oil Fillers etc. carefully before lubricating.

In addition to the Nipples, Oil Fillers etc. indicated in the Lubrication Diagram the following parts must be provided with a few drops of oil every 1 000 km (600 miles):

the fulcrums of Hand Controls on Handlebar,  
and Gear Rigging.



## 24. Survey of Maintenance Works

In addition to the Lubrication works indicated in the Lubrication Diagram the following maintenance works must be performed regularly.

The right-hand column indicates the pages on which you will find more information on maintenance works specified in the center column.

| mileage                  | Type of work   | Page |
|--------------------------|--|------|
| 1000 km =<br>600 miles   | Service Oil Air Cleaner . . . . .                    | 24   |
|                          | Retighten Cylinder Flange and Head Nuts . . . . .    | 23   |
|                          | Check Front Fork and Steering . . . . .              | 27   |
|                          | Check Battery . . . . .                              | 28   |
| 2000 km =<br>1200 miles  | Adjust Valve Play . . . . .                          | 23   |
|                          | Service Carburettor . . . . .                        | 24   |
| 5000 km =<br>3000 miles  | Retighten Frame Clamping Screws . . . . .            | 28   |
|                          | Clean Breaker Contacts and Plugs . . . . .           | 25   |
|                          | Check gap between Plug Electrodes . . . . .          | 25   |
| 10000 km =<br>6000 miles | Service Oil Sump and Oil Strainer . . . . .          | 23   |
|                          | Check Battery-Lighting Set and Grease Felt . . . . . | 24   |
|                          | Check Brakes . . . . .                               | 27   |
|                          | Check Lighting Equipment . . . . .                   | 24   |

## 25. Lubrication Diagram

| mileage                                    | type of lubricating point          | No. | type of lubricant   | type of work   |
|--|------------------------------------|-----|---|--|
| 500 km<br>or<br>300 miles                  | Oil Filler on Crankcase            | 1   | Mobiloil AF = SAE 40 above plus 15° C   | Check Oil Level<br>If necessary, refill  |
|  | Oil Filler on Gearbox              | 1   | Mobiloil Artic = SAE 20 below plus 15° C  |  |
|  | Oil Filler on Rear Wheel Gear Unit | 1   | Mobiloil CW=SAE 90  |  |
| 1500<br>3000 km<br>or<br>1800 miles<br>900 | Oil Filler on Crankcase            | 1   | Motoroil  | Oil Change:<br>Take off Oil Drain Plug, drain out oil with Engine still warm, screw in Drain Plug. Add 2 liters of Oil               |
| 5000 km<br>or<br>3000 miles                | Front Wheel Brake Flange           | 1   | Mobilcompound Nr. 4   | Clean Pressure Nipples and inject  |
|  | Foot Brake Lever Foot-Change Shaft | 2   |   |  |
|  | Rear Wheel Springing               | 2   |   |  |
|  | Universal Joint Shaft              | 2   | Mobilcompound Nr. 5   |  |
|  | Tele-Glide Fork                    | 2   | Mobiloil AF = SAE 40 above plus 15° C<br>Mobiloil Artic = SAE 20 below plus 15° C | Oil Change:<br>Detach Drain Plugs. Drain out oil. Screw in Plugs again. Refill 150 c. c. of oil into each Fork Prong.                |
| 10000 km<br>or<br>6000 miles               | Oil Filler on Gearbox              | 1   | Motoroil  | Oil Change:<br>Take out Oil Drain Plug, drain out Oil with Engine still warm, screw in Oil Drain Plug, and refill 0.75 liters of oil |
|  | Oil Filler on Rear Wheel Gear Unit | 1   | Mobiloil CW=SAE 90  | Oil Change:<br>Take out Oil Drain Plug, drain out Oil with Engine still warm, screw in Plug, and refill 0.18 liters of oil           |



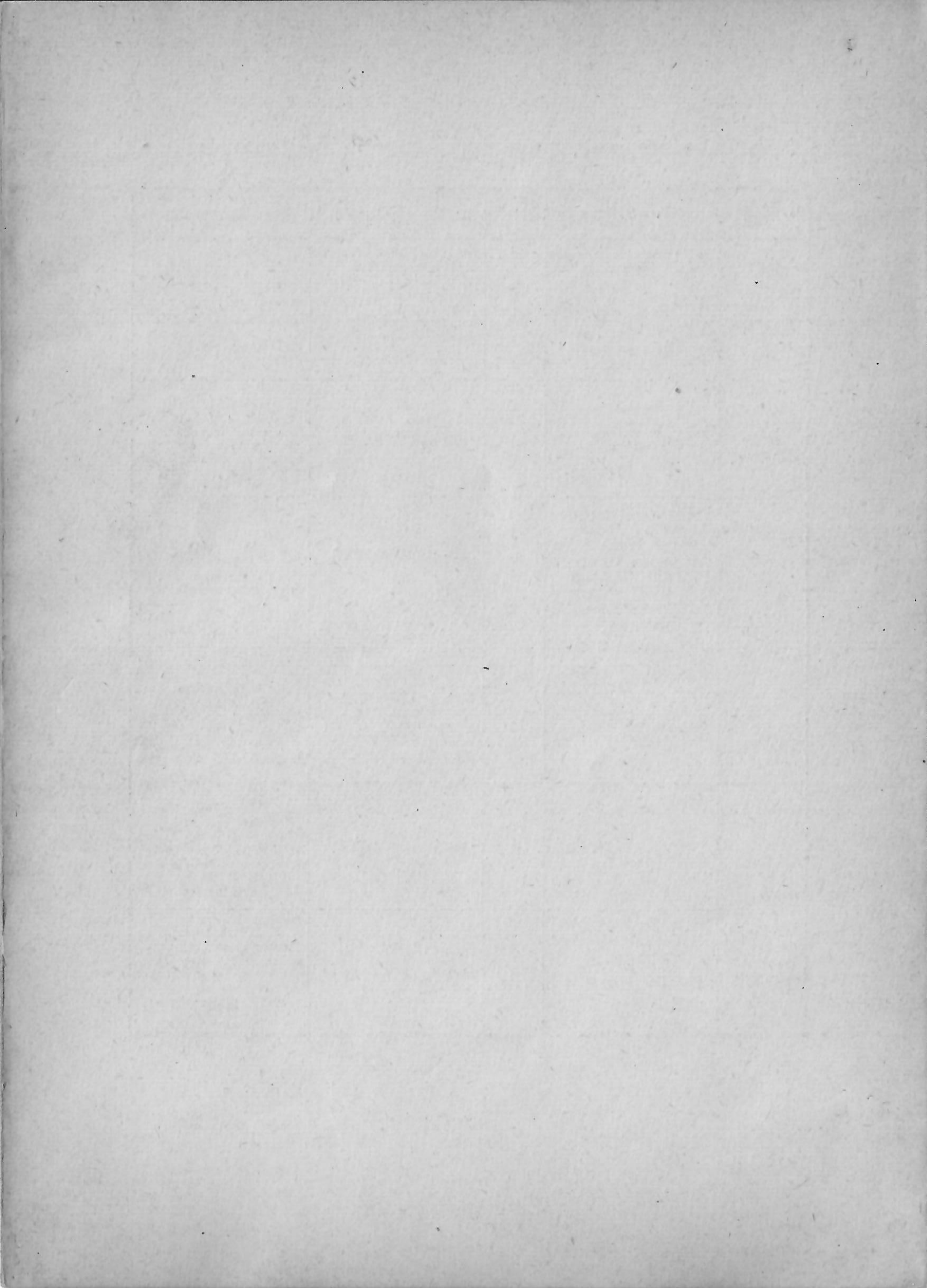
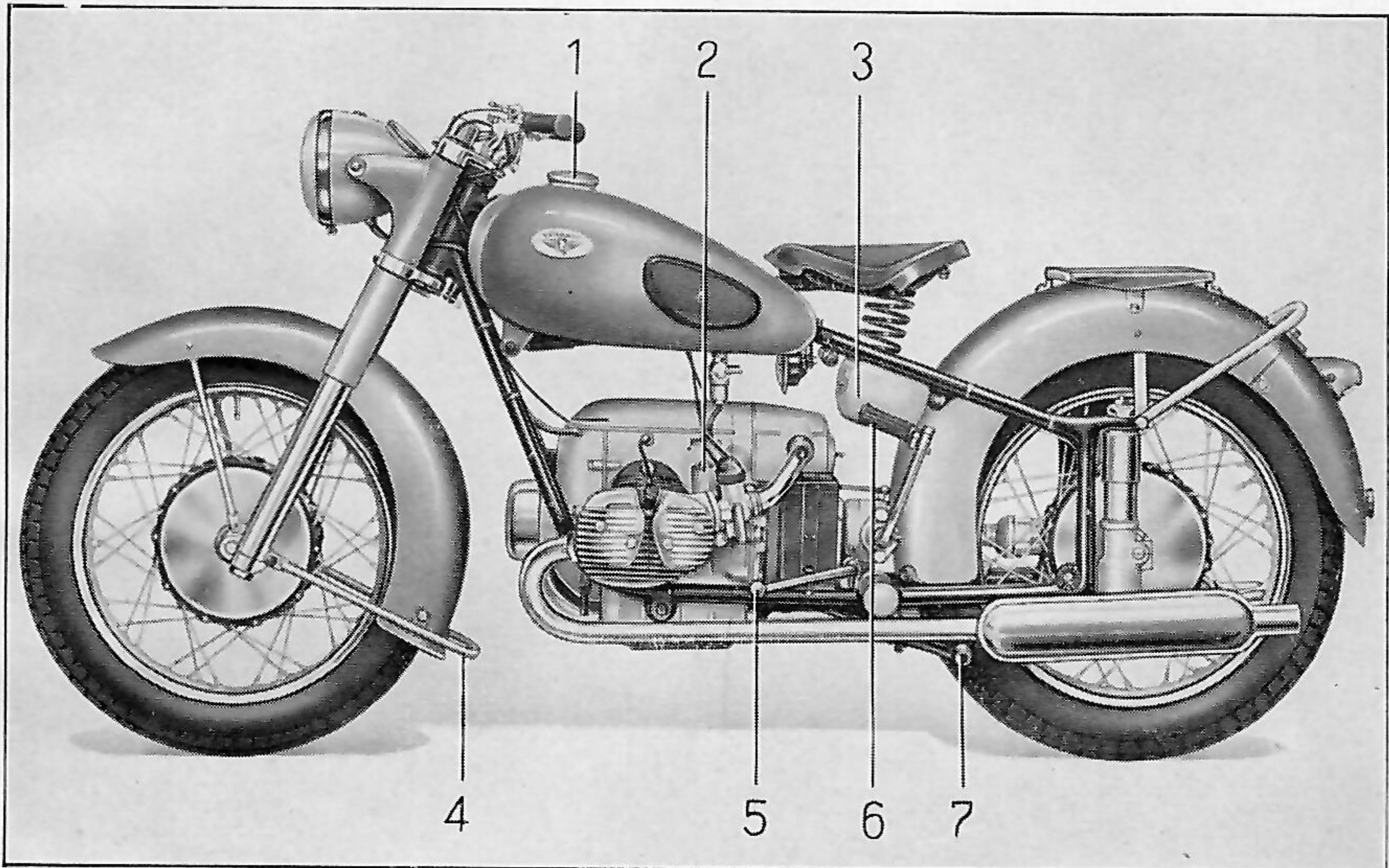



Fig. 1



Motorcycle, left-hand view

- |                              |                     |
|------------------------------|---------------------|
| 1 Fuel Tank Cap              | 5 Foot-Change Lever |
| 2 Oil Filler Screw on Engine | 6 Starter           |
| 3 Toolbox                    | 7 Center Stand      |
| 4 Front Stand                |                     |



Fig. 2

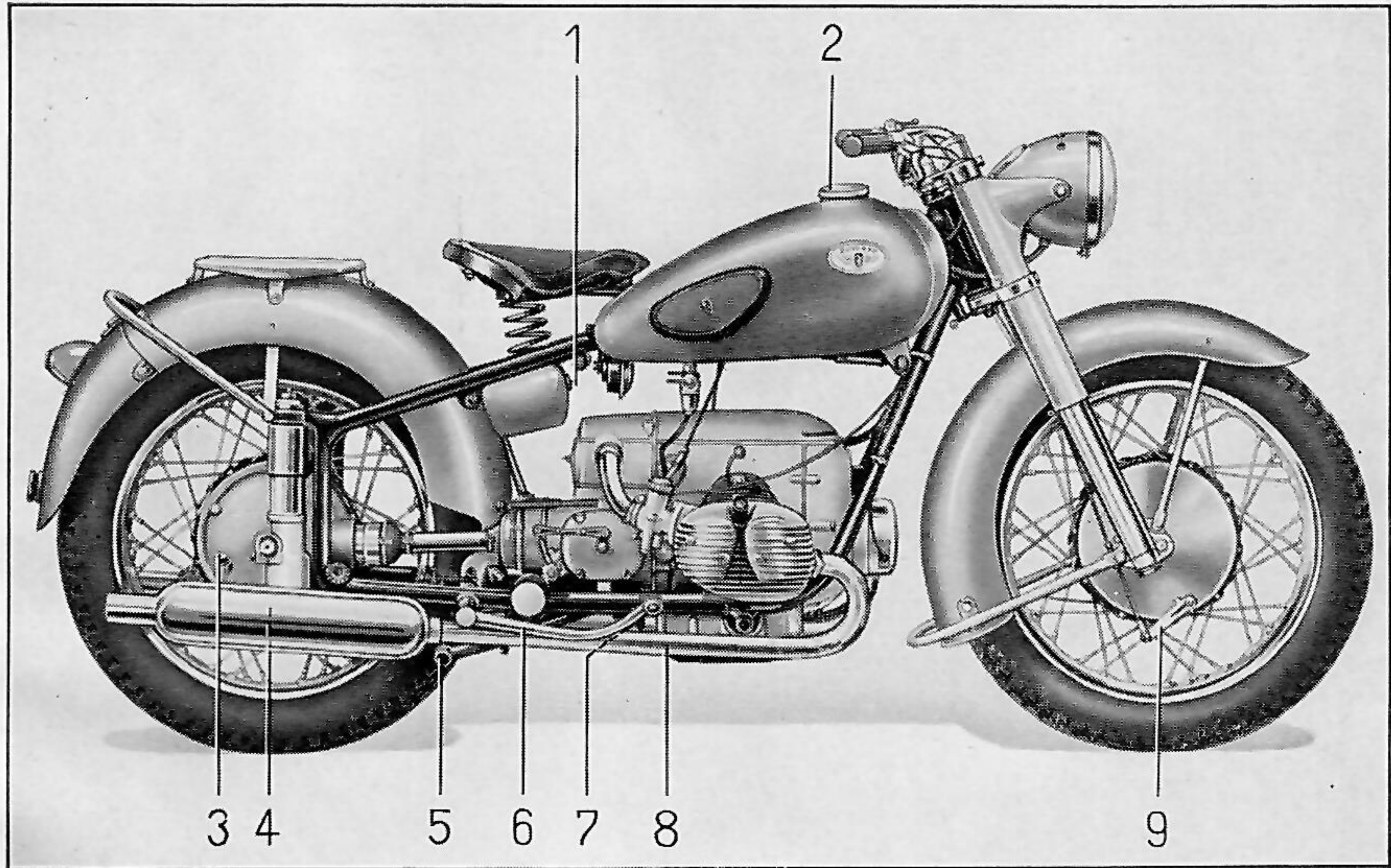

Motorcycle, right-hand view

- 1 Distribution Box for Sidecar Light
- 2 Fuel Tank Cap
- 3 Oil Filler Screw for Final Drive Unit
- 4 Oil Drain Plug for Final Drive Unit

- 5 Center Stand
- 6 Brake Pedal
- 7 Oil Drain Plug for Gear Unit
- 8 Oil Drain Plug for Engine
- 9 Front Wheel Brake Lever Bar



Fig. 3

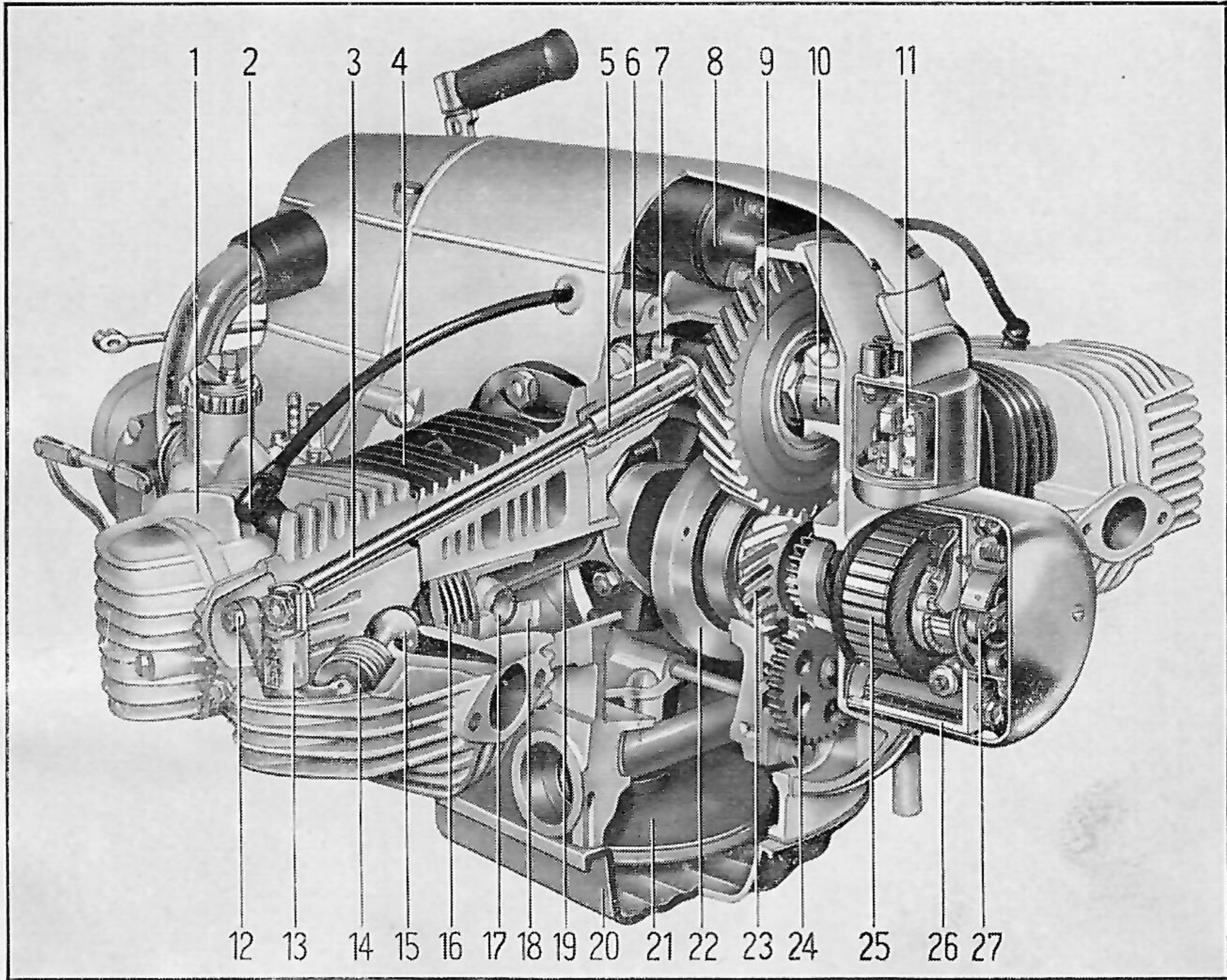

Engine, sectional view

- |  |                      |
|--|----------------------|
| 1 Right-hand Cylinder Head                           | 14 Valve Spring      |
| 2 Sparkplug with Cap                                 | 15 Valve             |
| 3 Pushrod  | 16 Compression Rings |
| 4 Right-hand Cylinder                                | 17 Piston Pin        |
| 5 Mushroom Tappet                                    | 18 Piston            |
| 6 Tappet Guide                                       | 19 Connecting Rod    |
| 7 Camshaft   | 20 Oil Sump          |
| 8 Ignition Coil                                      | 21 Oil Filter        |
| 9 Camshaft Gear                                      | 22 Crankshaft        |
| 10 Breather  | 23 Crankshaft Gear   |
| 11 Voltage Regulator with<br>Reserve Current Cut-Out | 24 Oil Pump          |
| 12 Valve Adjusting Screw                             | 25 Armature          |
| 13 Rocker Arm  | 26 Generator         |
|  | 27 Contact Breaker   |



Fig. 4

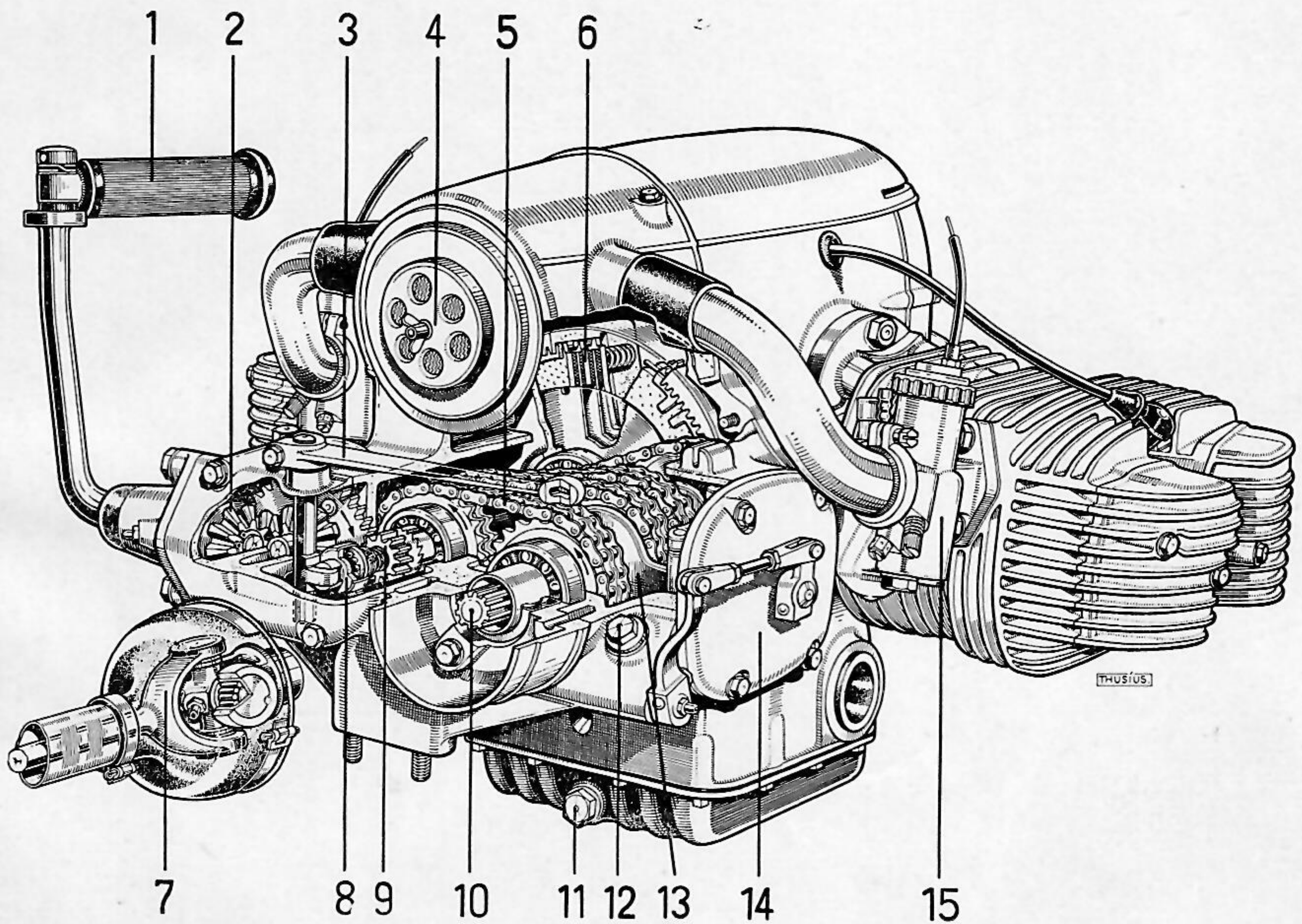

Engine with Change Speed Gear, sectional view

- |                         |                                   |
|-------------------------|-----------------------------------|
| 1 Starter               | 9 Main Shaft                      |
| 2 Starter Bevel Gears   | 10 Reduction Shaft                |
| 3 Clutch Lever Bar      | 11 Oil Drain Plug for Engine      |
| 4 Air Filter            | 12 Oil Filler Screw for Gear Unit |
| 5 Duplex Chain Drive    | 13 Shifting Fork                  |
| 6 Multiple Disc Clutch  | 14 Gearshifting Mechanism         |
| 7 Universal Joint Shaft | 15 Carburettor                    |
| 8 Clutch Thrust Bearing |                                   |



Fig. 5

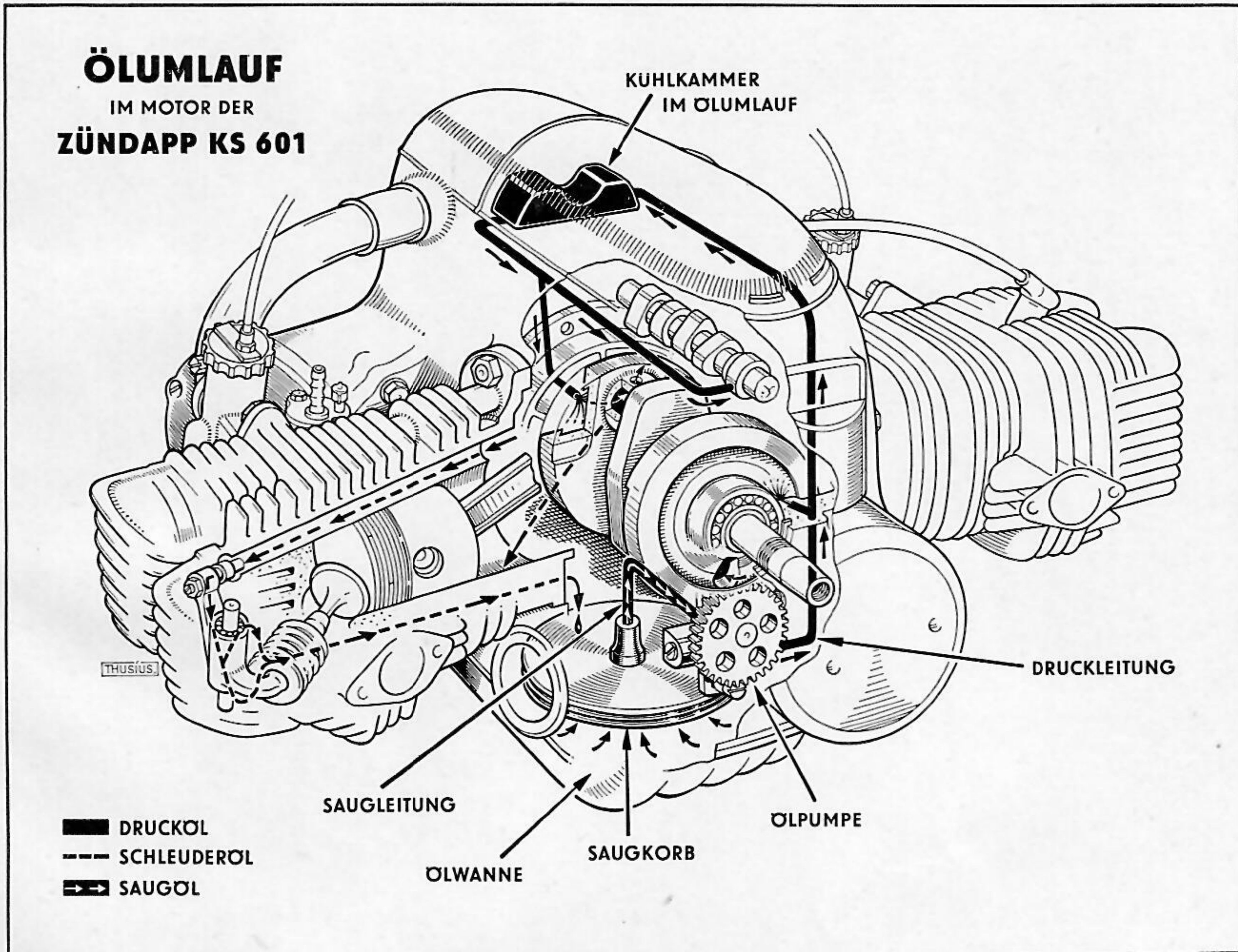

### Oil Circulation within Engine

|                       |                    |
|-----------------------|--------------------|
| Kühlkammer im Ölumlau | = Oil Cooling Unit |
| Saugleitung           | = Suction Pipe     |
| Ölwanne               | = Oil Sump         |
| Saugkorb              | = Oil Filter       |
| Ölpumpe               | = Oil Pump         |
| Druckleitung          | = Pressure Pipe    |
| Drucköl               | = Pressure Oil     |
| Schleuderöl           | = Oil Splash       |
| Saugöl                | = Suction Oil      |



Fig. 5

new  
nouveau  
nuevo

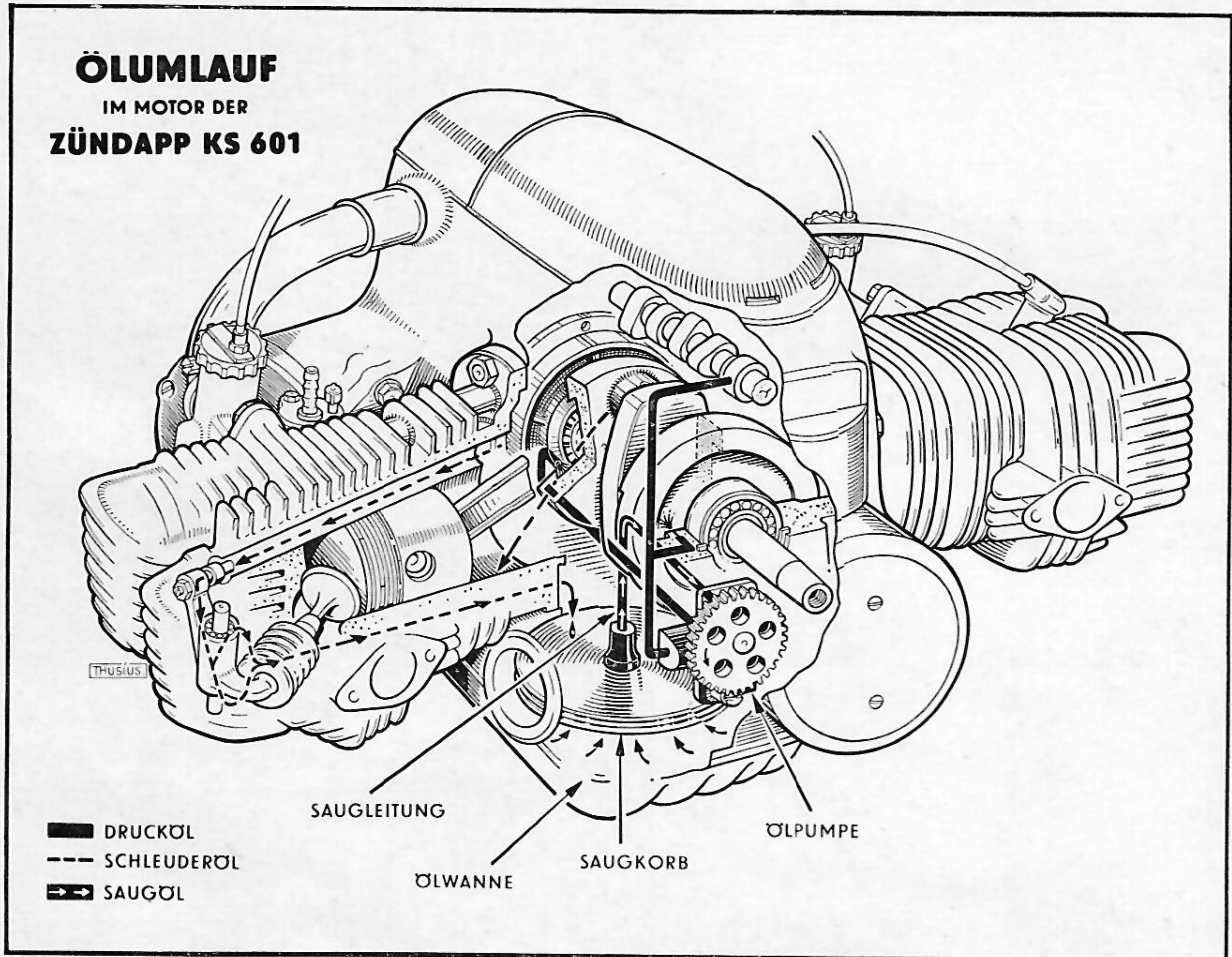

**Oil Circulation within Engine**

Circulation d'huile dans le moteur — Circulación de aceite en el motor

|             |                |                         |                         |
|-------------|----------------|-------------------------|-------------------------|
| Saugleitung | = Suction Pipe | — Conduite d'aspiration | — Tubería de aspiración |
| Ölwanne     | = Oil Sump     | — Carter inférieur      | — Carter                |
| Saugkorb    | = Oil Filter   | — Filtre à huile        | — Cesta de aspiración   |
| Ölpumpe     | = Oil Pump     | — Pompe à huile         | — Bomba de aceite       |
| Drucköl     | = Pressure Oil | — Huile de pression     | — Aceite de presión     |
| Schleuderöl | = Oil Splash   | — Huile de projection   | — Aceite lanzado        |
| Saugöl      | = Suction Oil  | — Huile d'aspiration    | — Aceite de aspiración  |



Fig. 6

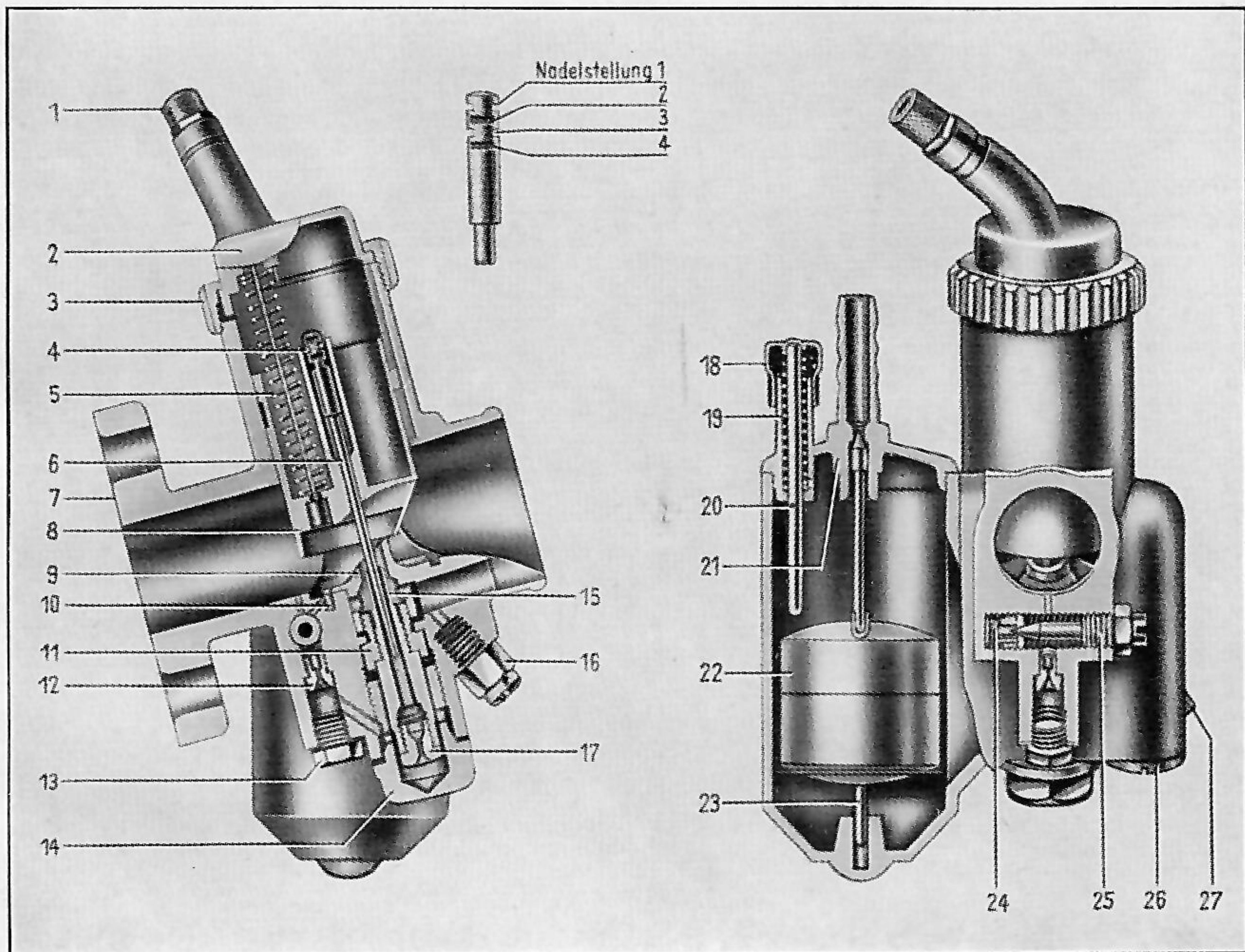

Carburettor, sectional view

- |                           |                          |
|---------------------------|--------------------------|
| 1 Cable Adjusting Screw   | 15 Needle Jet            |
| 2 Cover Plate             | 16 Protector Screw       |
| 3 Cover Plate Union Piece | 17 Main Jet              |
| 4 Clamp                   | 18 Tickler               |
| 5 Gas Slide Spring        | 19 Tickler Spring        |
| 6 Jet Needle              | 20 Split Cotter Pin      |
| 7 Carburettor Body        | 21 Float Chamber Cover   |
| 8 Gas Slide               | 22 Float                 |
| 9 Mixing Chamber Insert   | 23 Float Spindle         |
| 10 Compensator Bore       | 24 Idler Air Jet         |
| 11 Thread                 | 25 Air Adjusting Screw   |
| 12 Idler Jet              | 26 Screw Plug            |
| 13 Screw Plug             | 27 Idler Adjusting Screw |
| 14 End Screw              |                          |



Fig. 7

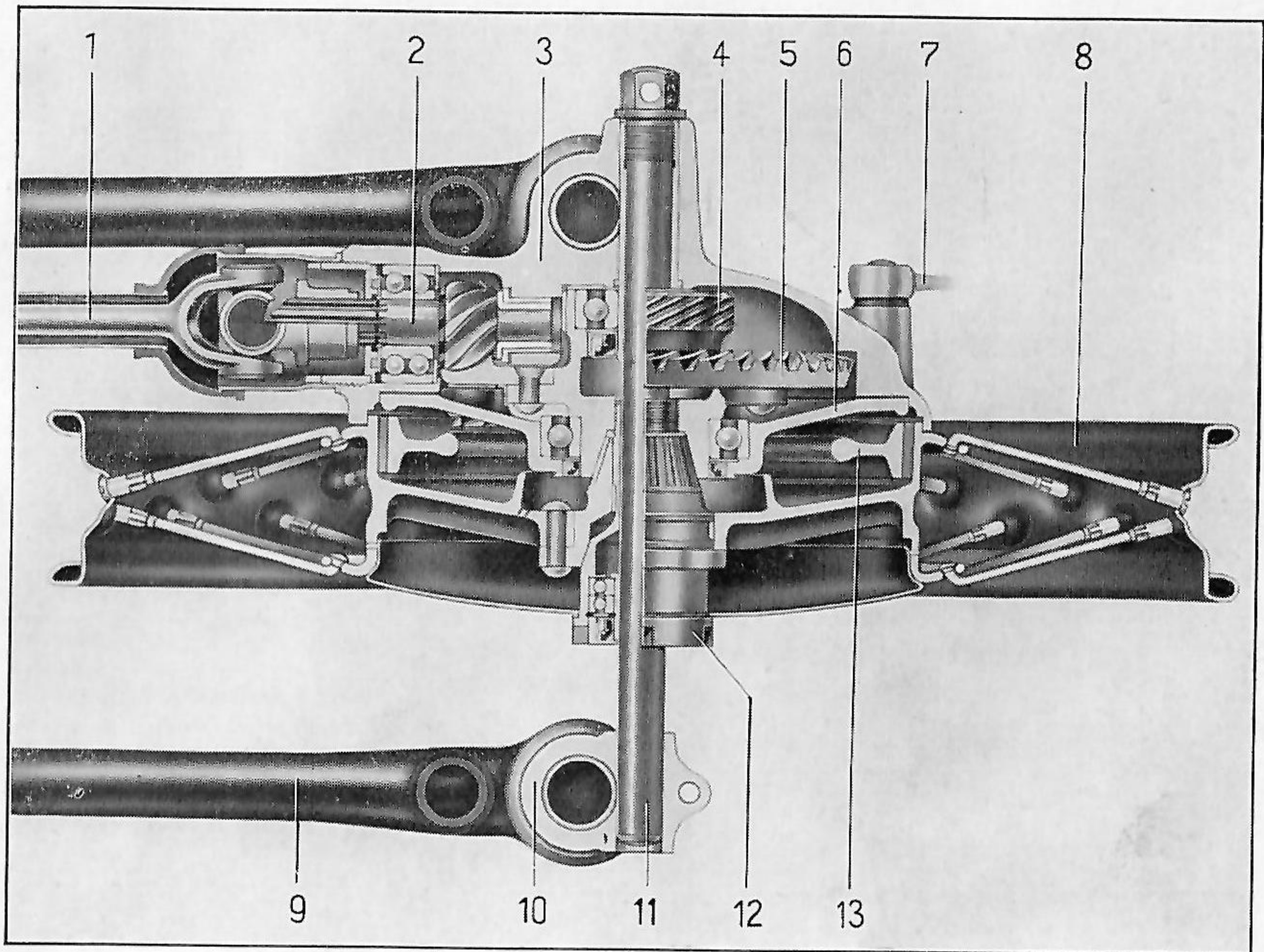

Final Drive Unit, sectional view

- |                                |                    |
|--------------------------------|--------------------|
| 1 Universal Joint Shaft        | 8 Rear Wheel       |
| 2 Driver Bevel Gear            | 9 Frame            |
| 3 Final Drive Unit Casing      | 10 Spring Tube     |
| 4 Driving Gear for Speedometer | 11 Rear Wheel Axle |
| 5 Spiral Drive Gear            | 12 Clamping Bush   |
| 6 Casing Cover                 | 13 Brake Shoes     |
| 7 Brake Lever Bar              |                    |



Fig. 8

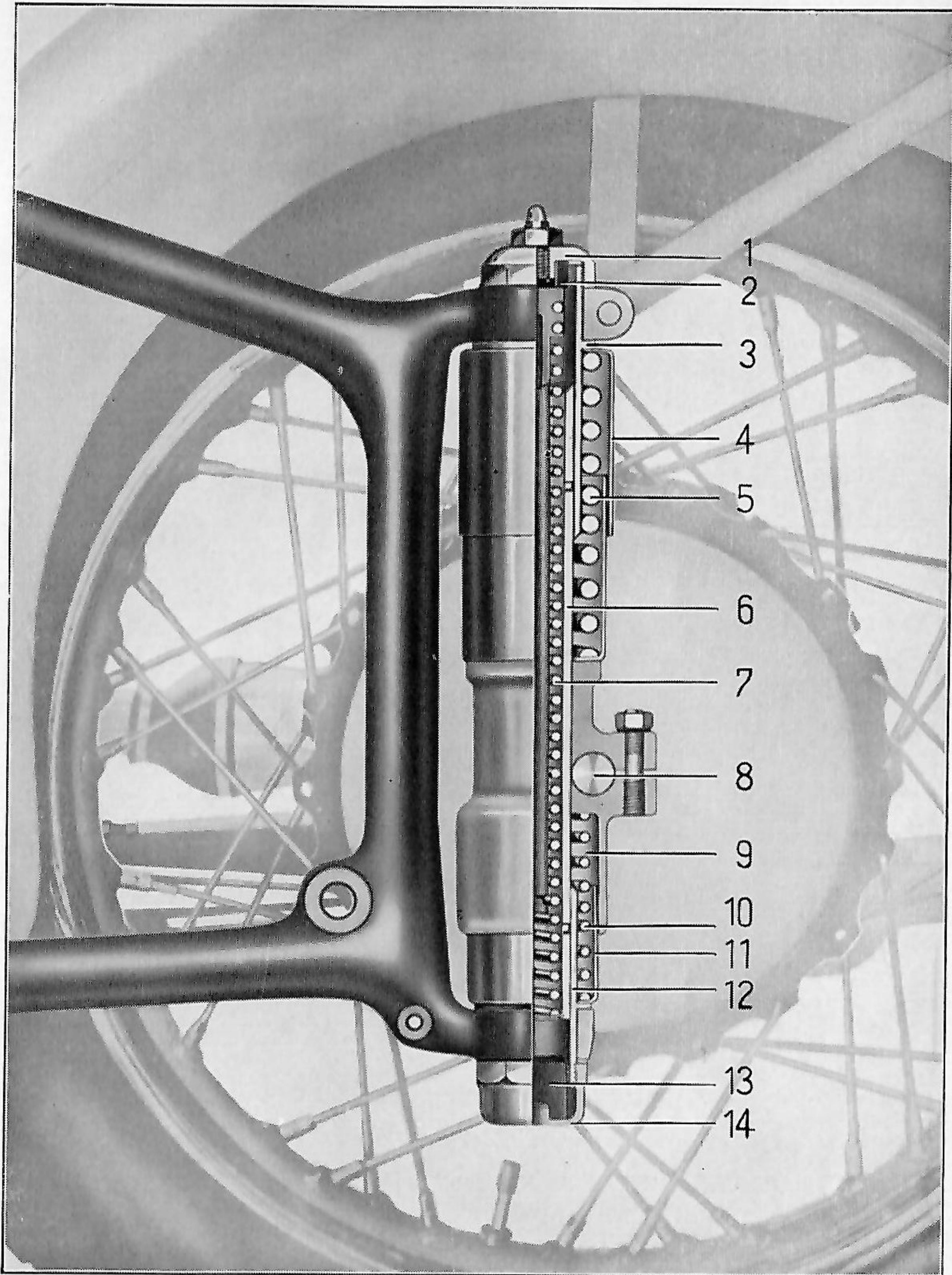

Rear Wheel Suspension, sectional view

- |                      |                          |
|----------------------|--------------------------|
| 1 Upper Lock Nut     | 8 Rear Wheel Axle        |
| 2 Rubber Ring        | 9 Casing                 |
| 3 Sliding Bush       | 10 Counter-action Spring |
| 4 Protector Cap      | 11 Protector Cap         |
| 5 Main Spring        | 12 Lower Sliding Bush    |
| 6 Guide Tube         | 13 Rubber Bumper*)       |
| 7 Auxiliary Spring*) | 14 Lower Lock Nut        |

\*) No longer built in on new models



Fig. 9

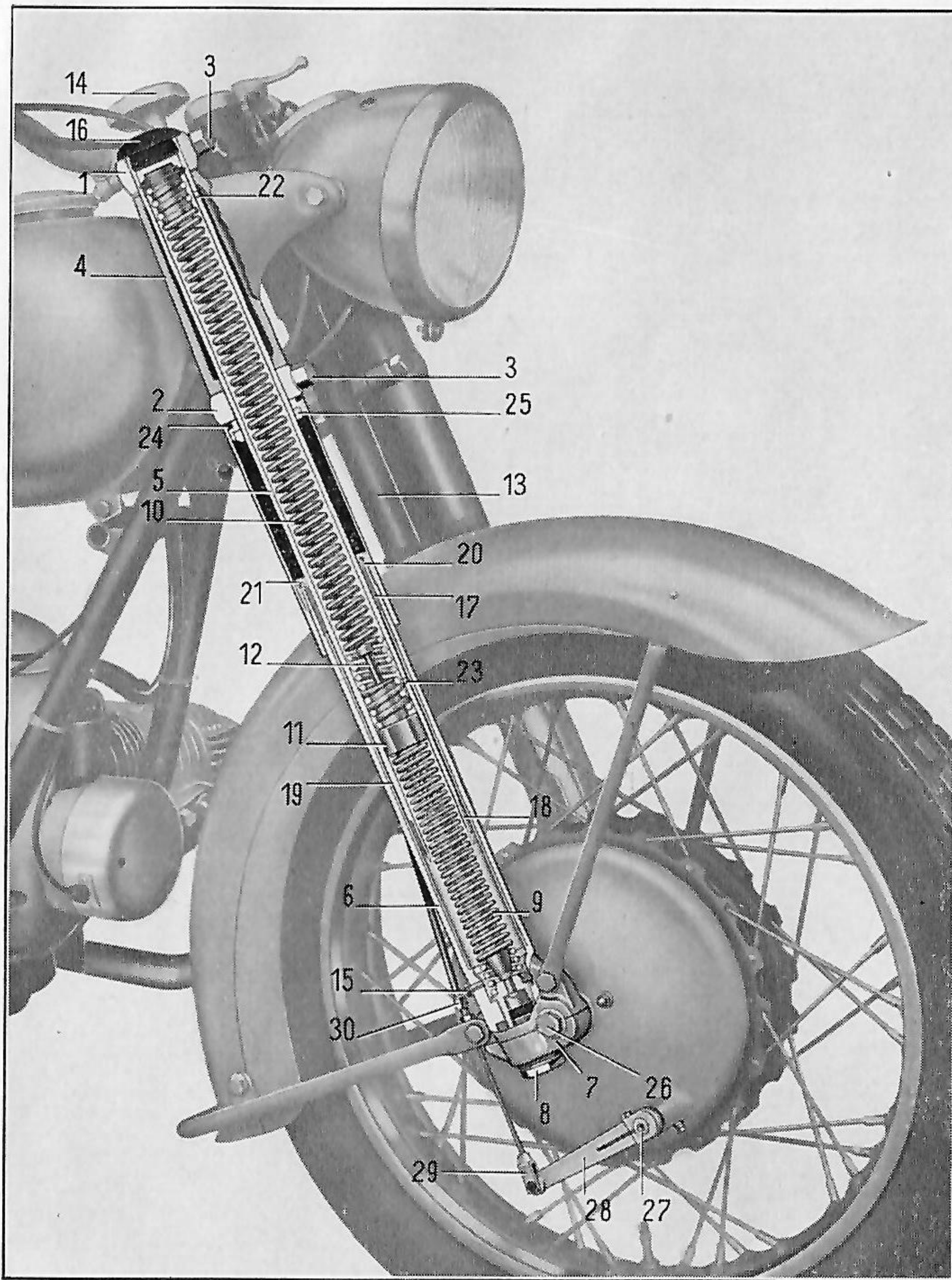

Telescopic Front Fork and Front Wheel Brake

- |                                 |                       |
|---------------------------------|-----------------------|
| 1 Upper Fork Cross Member       | 16 Rubber Stopper     |
| 2 Lower Fork Cross Member       | 17 Upper Sliding Bush |
| 3 Clamping Screw                | 18 Lower Sliding Bush |
| 4 Headlight Support             | 19 Sleeve             |
| 5 Fork Tube                     | 20 Spring Nut         |
| 6 Fork Guide Tube               | 21 Packing Ring       |
| 7 Jaw                           | 22 Air Vent           |
| 8 Clamping Bolt                 | 23 Lubrication Point  |
| 9 Short Spring                  | 24 Rubber Ring        |
| 10 Long Spring                  | 25 Bumper             |
| 11 Spring Seat                  | 26 Lock Bolt          |
| 12 Tension Bolt                 | 27 Brake Toggle       |
| 13 Oil Cushioned Shock Absorber | 28 Brake Lever Bar    |
| 14 Steering Damper              | 29 Forked Joint       |
| 15 Oil Drain Plug               | 30 Adjusting Screw    |



Fig. 10

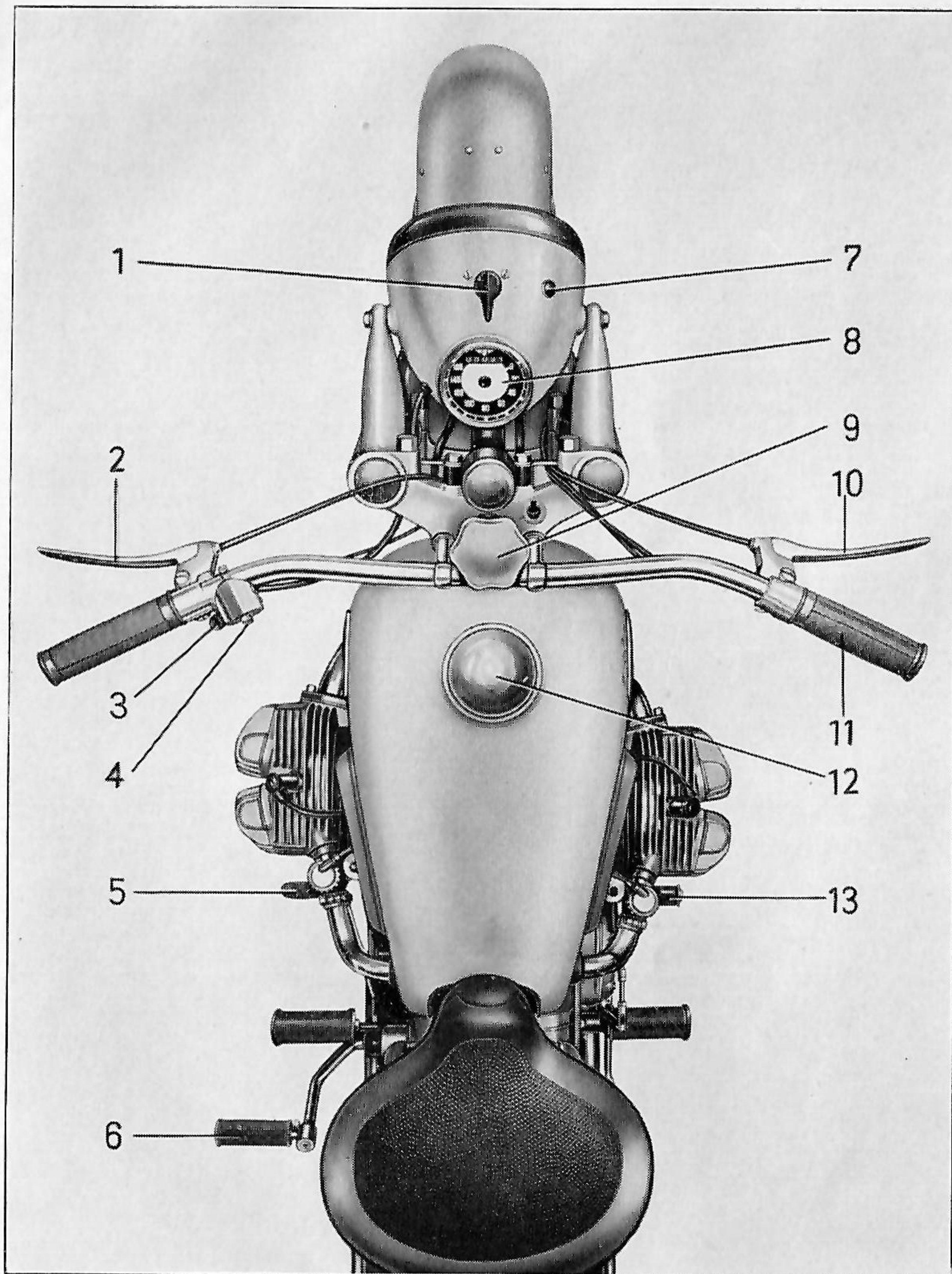

Hand and Foot Controls

- 1 Electrolock
- 2 Clutch Hand Control
- 3 Dipper
- 4 Horn Button
- 5 Foot-Change Lever
- 6 Starter
- 7 Ignition Warning Light

- 8 Speedometer
- 9 Steering Damper
- 10 Hand Brake Lever
- 11 Twist Grip
- 12 Fuel Tank Cap
- 13 Brake Pedal



Fig. 11

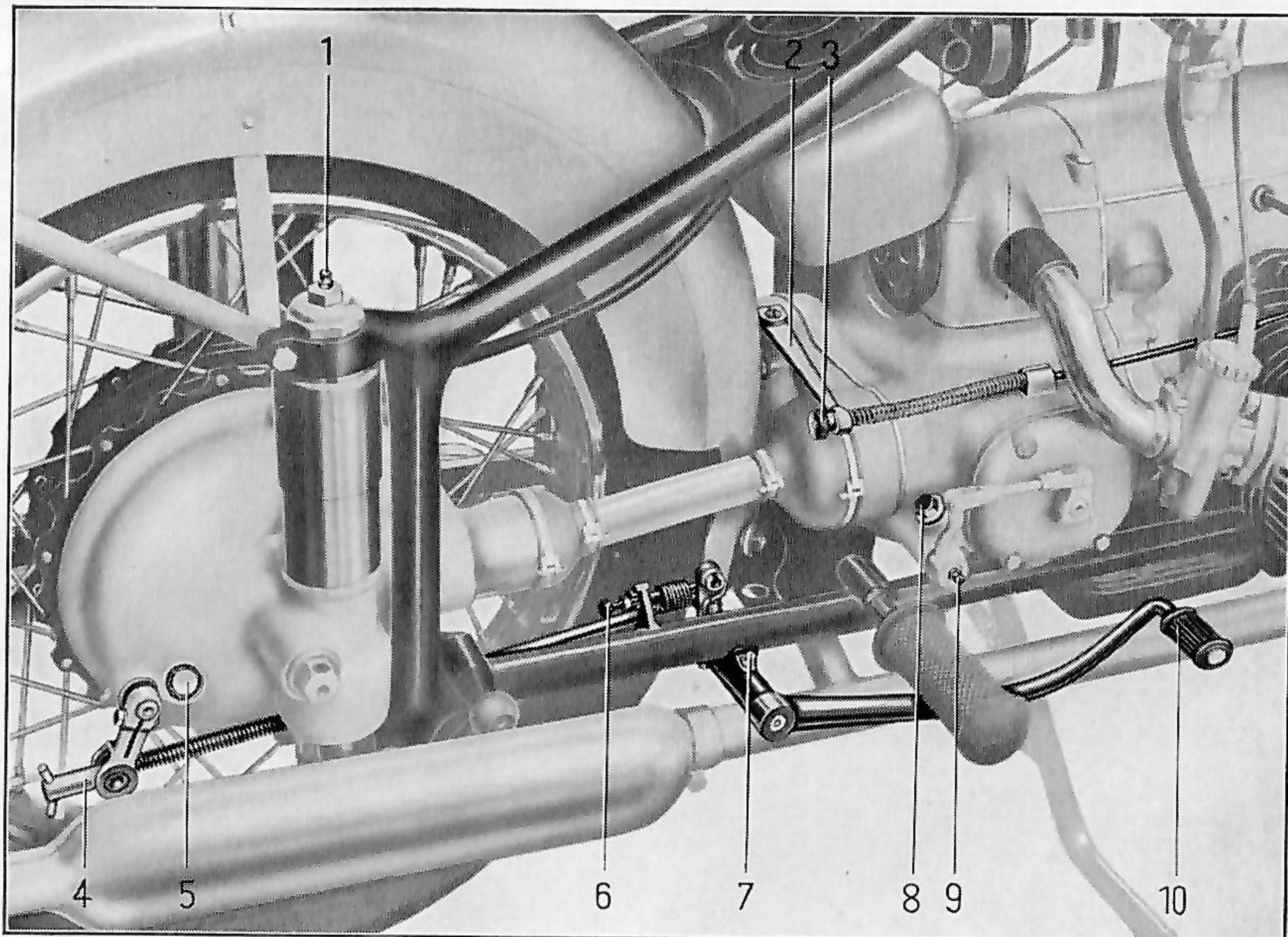

### Brake and Clutch Controls

- |   |  |
|---|--|
| 1 Pressure Grease Nipple for Rear Wheel Springing | 6 Stop Screw for Brake Pedal                   |
| 2 Clutch Lever Bar                                | 7 Pressure Grease Nipple for Foot Brake Shaft  |
| 3 Knurled Edge Nut (for Clutch adjustment)        | 8 Oil Filler Screw for Gear Unit               |
| 4 Toggle Nut (for Foot Brake adjustment)          | 9 Pressure Grease Nipple for Foot-Change Shaft |
| 5 Oil Filler Screw for Final Drive Unit           | 10 Brake Pedal                                 |







